

elektor

up-to-date electronics for lab and leisure

D 71683

96

April 1983

75 p.

IR 112p. (incl. VAT)
\$2.50

AIR-MAIL COPY

Smile High

Programmable timer/controller

The keyboard is part of the front panel!

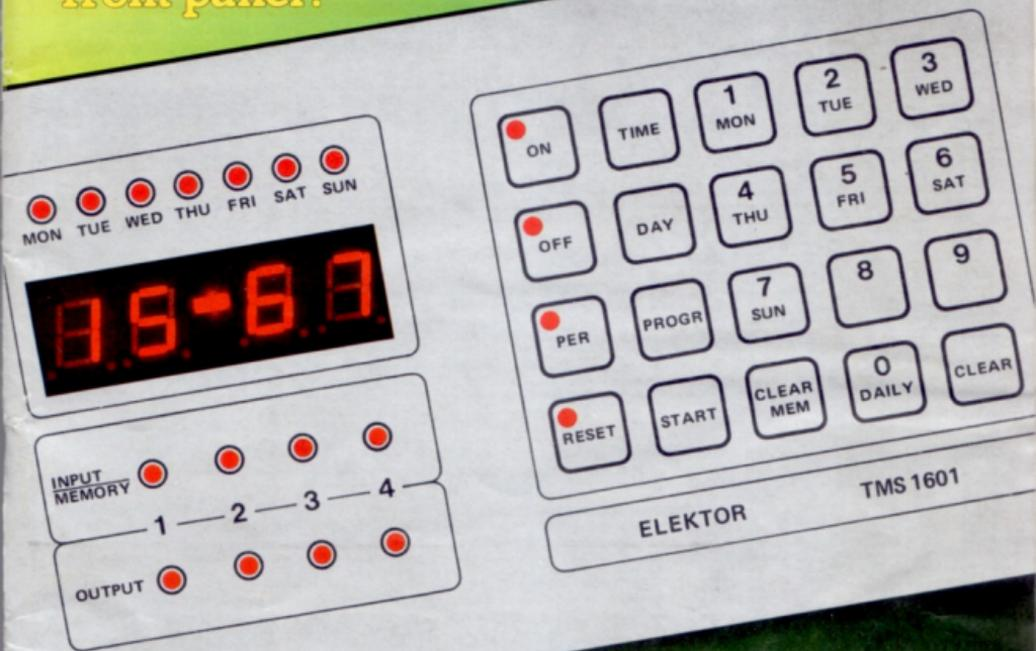

darkroom timer
remote control audio
compact LCD thermometer

contents

AIR-MAIL COPY

selektor	4-20
low-power digital thermometer	4-22
E. Schmidt The thermometer described in this article can be operated continuously for more than six months without changing the battery. That is quite an achievement and already makes our last thermometer circuit appear a little obsolete!	
MC/MM phono preamp	4-26
The phono preamp is an important part of the Prelude, or indeed of any audio system. Most really good cartridges are the moving coil type, and these require a step-up transformer or, as is more common nowadays, a so-called pre-preamp. The phono preamp and the moving coil pre-preamp described in this article are designed to form a single module. This can be incorporated in any audio system, although it is intended as part of the Prelude.	
technical answers	4-33
National filter with application fault; marking of digitast switches; slave flashgun powered by the mains; Crescendo coils and S/N ratio.	
membrane switches	4-34
The membrane switch — or foil switch as it is becoming popularly known — is almost too good to be true. The switch is both reliable and inexpensive. These two factors coupled with its 'science fiction' appearance can provide the basis for a very elegant and economical keyboard that the more conventional switch cannot hope to match.	
interlude	4-36
The convenience of remote-control for television sets is fairly well-known. The Interlude brings the same armchair operation to the world of hi-fi audio: volume, balance, tone, even input select — all controlled from the 'ideal listening position'.	
RC equalizer	4-40
7-day timer/controller	4-42
The last time we published a single-chip programmable timer was way back in May 1979 and the circuit became very popular (and still is). However, the IC used at the time is now a little 'thin on the ground' and it's about time the subject was brought up to date. The circuit here uses the TMS 1601 from Texas Instruments, a single-chip microcomputer specifically designed for this purpose.	
junior program tester	4-51
P. Wild	
Prelude (Part 3)	4-52
The end is in sight! We have now reached the final constructional article in the Prelude series: the printed circuit board for the tone control.	
programmable darkroom timer	4-56
Many amateur photographers will be interested in this circuit: a programmable timer for seven preselectable times. The time can be adjusted in two ranges (up to 99.9 s and up to 999 s). Fourteen keys are used for programming. When the start key is pressed, the time countdown can be observed on the display.	
talking-clock extension	4-60
E.A.J. Bogers	
market	4-61
switchboard	4-65
EPS service	4-80
advertisers index	4-82

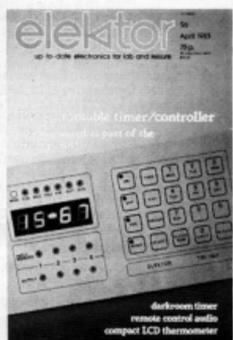

The front panel for the 7-day timer/controller includes a membrane-switch keypad and red translucent windows for the LEDs and display. Anyone who happens to notice something out of the ordinary in the time display is referred to the top right-hand corner of this month's cover.

Sumich
March 23, 1983

B.K. ELECTRONICS

SPECIAL OFFER

DIGITAL CAPACITANCE METER

LCD DIGITAL MULTITESTER

MINIATURE AUTORANGING D.M.M.



DM 2350/C

KD615

DM 6013

INCLUSIVE OF
POST & PACKING
AND V.A.T.

DM6013 DIGITAL CAPACITANCE METER

£52.75

High accuracy measurement of capacitance over a wide range of values. Fast sample time, easy to read LCD display. Rugged construction — easy operation.

Display: 3½ digit LCD x 13 mm to 1999
 Ranges: 8 ranges, full scale values 200pF to 2000µF
 Sample time: 0.5 second
 Measurement capability: 0.1pF to 2000µF
 Accuracy: 0.5% full scale ± 1 digit

Features: Zero adjustment; overload protection, side switches for single-handed operation
 Accessories: Pair test leads with alligator clips, spare fuse
 Power: 1 x PP3 battery (not supplied)
 Calibration: By internal adjustment
 Dims: 175 x 80 x 35 mm

KD615 LCD DIGITAL MULTITESTER

£39.99

Multifunction 3½-digit tester including transistor tester and 10A d.c. range. Over-range, low battery and polarity indication. Full fuse overload protection. Supplied complete with carrying case, test leads, battery and instruction manual.

d.c. Volts: 0.2 – 2 – 20 – 200 – 1000V
 ± 0.8% Impedance 10M
 d.c. Amps: 0.2mA – 2mA – 20mA – 200mA
 ± 1.2%; 10A ± 2%
 a.c. Volts: 200 – 750V ± 1.2% – Impedance 5M

Resistance: 200 ohms – 2k – 20k – 200k – 2M – 20M ohms ± 1%
 Transistor check: hFE 0 – 1000 PNP or NPN; IBE 10µA, VCE 2.8V.
 Dims: 196 x 93 x 42mm

DM2350/C MINIATURE AUTORANGING D.M.M.

£52.00

Super compact autoranging digital multimeter featuring continuity buzzer and large (10mm) clear 3½-digit display. Full fuse overload protection. Carrying case, leads, battery, spare fuse and instruction manual supplied.

d.c. Amps: 0 – 200mA ± 1.2%; 20A with shunt (included)
 d.c. Volts: 0.2 – 2 – 20 – 200 – 1000V
 ± 0.8% Impedance 10M
 a.c. Amps: 0 – 200mA ± 1.4%. 20A with shunt (included)

a.c. Volts: 2 – 20 – 200 – 600V ± 1.0%
 Impedance 10M
 Resistance: 200 ohms – 2k – 20k – 200k ± 0.8%
 2M ohms ± 2%
 Dims: 130 x 65 x 20mm

B.K. ELECTRONICS

UNIT 5, COMET WAY, SOUTHEND ESSEX, SS2 6TR.

★ SAE for current lists. ★ Official orders welcome. ★ All prices include VAT.
 please phone 0702-527572.



**METERTECH
DIGITAL MULTIMETER
MODEL DMM 3T
£49.95**



BOTH UNITS FEATURE
13 mm (0.5") LCD DISPLAY
SIZE 180 x 90 x 35 mm
BATTERY LOW INDICATION
FUSE CIRCUIT PROTECTED
OVER RANGE INDICATION
POWER SUPPLY 9 V DC BATTERY
BATTERY LIFE 200 HOURS
WEIGHT 300 g. INC. BATTERY
LOW POWER CONSUMPTION
PUSH BUTTON CONTROLS
ACCESSORIES INCLUDED
TEST LEADS
BATTERY
INSTRUCTION MANUAL.

DMM 3T

10 M Ω INPUT IMPEDANCE
AUTO ZERO ADJUSTMENT
AUTO POLARITY SWITCHING
hFE MEASUREMENT FACILITY
DIODE/CONTINUITY CHECK
SAMPLING TIME 0.25 SEC.
DC VOLTAGE (5 RANGES) 100 μ V to 1000 V
AC VOLTAGE (2 RANGES) 100 mV to 1000 V
DC CURRENT (5 RANGES) 100 nA to 10 A
RESISTANCE (4 RANGES) 1 Ω to 2 M Ω

OPTIONAL ACCESSORIES

PROTECTIVE CASE £6.95
10 mA-10 A AC CURRENT SHUNT £6.95
THERMOCOUPLE INTERFACE £39.95
(-50 to 1100°C x 1°C 1% ACCURACY)
EXPOSED JUNCTION THERMOCOUPLE £3.95



**METERTECH
DIGITAL CAPACITANCE METER
MODEL DCM MT301
£79.95**

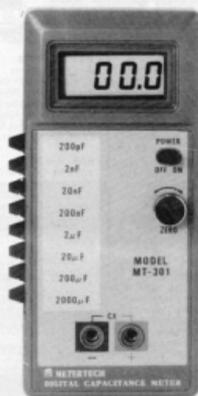

DCM MT 301

FRONT PANEL ZERO ADJUSTMENT
CRYSTAL TIME BASE
PROTECTED FROM CHARGED CAPACITORS
SAMPLING TIME 0.5 SEC.
CROCODILE CLIPS INCLUDED
8 RANGES 0.1 pF-2000 μ F
0.5% ACCURACY

RANGE	RESOLUTION	TEST FREQUENCY
200 pF	0.1 pF	800 Hz
2 nF	1 pF	800 Hz
20 nF	10 pF	800 Hz
200 nF	100 pF	800 Hz
2 μ F	1000 pF	800 Hz
20 μ F	0.01 μ F	80 Hz
200 μ F	0.1 μ F	8 Hz
2000 μ F	1 μ F	8 Hz

OPTIONAL ACCESSORIES PROTECTIVE CASE £6.95



**PRICES INCLUDE CARRIAGE AND VAT,
A VAT RECEIPT SUPPLIED WITH ALL ORDERS**

**62 CURTIS ROAD, HOUNSLOW, MIDDX, TW4 5PT
TELEPHONE 01-894-2723**

back number service

E24, April 1977
 Formant - The Elektor Synthesizer/Stereo Model Car Track (11)/More Decoder with dttl (2)/Display on Board/LED VU/PMA/Stereo/Injector/Simple Auto Slide Changer/Mini Drive for Light Sensor / Variometer Tuner (2)/Alter MA 11 - a,b,f,a.

E29, September 1977
 Introducing Microprocessors (1)/FM Mains Intercom/Working Recorder/Logarithmic Drumroom Timer/Monitor Switching for Two Tape Decks/CCIR TV Pattern Generator (1)/Formant - the Elektor Music Synthesizer (3).

E32, December 1977
 Analogue Frequency Meter/Experimenting with the SC/MP (2)/Dipoly Djingle Generator/Electret Microphone Pre-amplifier/ UHF TV Modulator/ Formant - the Elektor Music Synthesizer (6)/Heating Controller/ Stylus Balance Signal Injector/ Knotted Handkerchief/Sensitive Lightmeter/MW Reflex Receiver/Music Box.

E33, January 1978
 CMOS Noise Generator/Elektor Equaliser/Tar tip/Electronic Open Fire / Reel Programme Meter/L.A.A.180 LED Voltmeter/ Experimenting with the SC/MP (3)/Formant - the Elektor Music Synthesizer (7)/Simple Function Generator.

E34, February 1978
 Infra-red Light Gate/Throwing Some Light on LE Diodes/Formant - the Elektor Music Synthesizer (8)/Slow-mo/Off/CMOS Function Generator/Zener Tester/Development Timer/Experimenting with the SC/MP (4).

E35, March 1978
 Experimenting with the SC/MP (5)/SC/MP Power Supply/Curiosity Fashion Indicator/Colour TV Games/4 K RAM Card/Fun with a RAM/Electronic Music Formant - the Elektor Music Synthesizer (9)/Safety First.

E37, May 1978
 Aerial Systems for Satellite Communication/Digital Reverb Unit/Mini Short-wave Receiver/Vocoder (2)/Percolator Switch/Colour Modulator/ Circuit Boards and Soldering/Universal Logic Tester.

E38, June 1978
 1/4 GHz Counter/Constant Amplitude Squarewave to Sawtooth Converter/Servo Polarity Changer/ Monopoly Dice/ Mini Counter/Digital Clock Using the SC/MP/Programmable Call Generator/TV Sound Modulator/Automatic Stereo Switch/Traffic Light Controller/Easy Music.

E41, September 1978
 Purifier/ Oscilloscopes/ One Chip Does Not Make a Piano/ Master Tone Generator/Piano/ Temperature-controlled Soldering Iron/Car Start Booster/ 24 dB VCF/Buffered/Unbuffered CMOS.

E43, November 1978
 Cackling Egg Timer/ASCIIC Keyboard/Tag/Joysticks/Discople/Ring the Bell and Win a Prize/Extending the TV Booster/5 Duty-cycles at the Turn of a Switch/Hello, All You Folks Back Home/SC/MP Mastermind/TM Programme / Pocket Bagatelle.

E48, April 1979
 μ P TV Games/Car Light Remote/Stator/TAIP Switch/Action Delay Line (2)/CAPITALS for Master/Building the TV Games Computer.

E49, May 1979
 Programmable Timer/Controller/ Switching Mains-powered Equipment/Random Turn Doorbell/Extensor/Zero μ F Screen/Quiz Master/Building the TV Games Computer.

E50, June 1979
 Nicado/Elektorbell/Stereo Decoder/VHF Stereo Test Transmissions/Variable Logic Gate/FM IF Strip/Goodbye E300/E310 Hello 3000/310/Aquarium Thermostat/Monoslektor/Right-up and Left-down.

E53, September 1979
 Using an Equaliser/Monitor Output/Page Extension for Elektor/terminal-One mil for Audio/Parameter Equaliser/Audio Analyser /TAP Theives on the Head.

E54, October 1979
 Touch Tuning/Battery Saver/Impedance Bridge/New Programs for the SC/MP/Digital Rev Counter/Digital/Short-interval Light Switch/PCB for Variable Fuzz Box/Gate-clepper/Strain Gauge/1 Played TV Games/Programmable Sequencer.

E55, November 1979
 Topamp/Flash Sequencer/Electronics the Easiest Way/Remote Control Motor Switch/Home Trainer/Fuel Economiser/1 Played TV Games (2)/Short-wave converter/longsphere/low Voltage Dimmer/See your Point/Servo-controlled Motor.

E58, February 1980
 Aerial Booster/Fet Oamps in the Formant/TV Interference Suppression / Elektor Vocoder (2)/Aerial Amplifiers/Display/ Analogue Delay Technology/Extending the 1/4 GHz Counter/Digital Thermometer.

E63/64, July/August 1980
 Summer Circuits Double issue containing over 100 projects.

E65, September 1980
 8K RAM +48 or 16K EPROM on a Single Card/Precision Power Unit/Electronic Linear Thermometer/The Josephson Computer/VOX Printed Circuit Board/Elektor Measuring Multipath/High Speed Readout for Elektor/terminal/Musical Box/Electrolytology/Curve Tracer/Using the Vocoder.

E66, October 1980
 Programmable Slide Fader/Touch Doorbell/switched Capacitors/More TV Games/The Junior Computer/Memory Card/Remote Control Slide Projector/Video Pattern Generator/LCD Tuning Scale/Dual Slide Faders.

E67, November 1980
 An r.p.m. Indicator as an Economy Guide/Draught Detector/How to Recycle Dry Cell Batteries/Energy Saving Know-how/Simple Fuel Economy Meter/Automatic Pump Control/Long Life Technique in Light Bulbs/Automatic Curtain Control/Fridge Alarm/Keep the ins and outs of your Central Heating System/Energy Saving Motor Control/Coffee Machine Switch/Operational Hours Counter.

E68, December 1980
 Canned Circuits: 23 of the best entries which include Midnight Raid Detector/A Flash in the Car / Canometer / Canine Defence.

E70, February 1981
 Audio Power/Noise Reduction / Process Timer / High voltage from 723 / Juniors Growing Up/The Voiced/Unvoiced Detectors / Emergency Brake for the Power Supply/ 150 W DC to DC Converter for the Car/Low Noise 2 Metre Pre-Amp/2 Digit DVM/Magnephon.

E72, April 1981
 Transistor Match-maker/Universal Power Supply/Intelek/Humidity Sensor/Logic Analyser/II Crystal-controlled Stroboscope/Junior Cookbook.

E73, May 1981
 Compang Clock / Frequency Doubler/The Fully Fledged Junior Computer/Talk to Computers/Choke Alarm/Bar Codes/Logic Analyser/Waveform Generator/Sophisticated Software for the Junior Computer/Reading Bar Codes.

E77, September 1981
 DFM + DVM/Revolution Counter/Digital Barometer/IS Converter/TV Games Extended/ Disco Lights Controller/GUAD ESL/ES/Analogue LED Drive/ Volt/Ammeter for Power Supplies/Chattering Chips/Transistor Ignition Upgrade/Soldering Aluminium.

E89, September 1982
 Gas Detector/Rapid Loading Games/The Elektor Connection/ Inductive Sensor / Darkroom Computer Part 1 / Applikator/ Home Telephone System/Synthesised Sound Animation/Time Receiver for the Rugby MSF/ Three Phase Tester.

E90, October 1982
 DSB Demodulator/L.C.D. Thermometer/Ultra Sonic Distance Measurement/Electrolytic Run Dry/Darkroom Computer Part 2/Short Wave Band Shifting for SSB Receiver/16 Channels with only Five ICs/Pre-amp for the SSB Receiver / Active Aerial / Transistor and IC Data.

E91, November 1982
 Drum Interface/Talking Disc/ Model Train Lighting/Guitar Tuner/Cerberus/Floppy Disc Interface for the Junior/Cubular Bell/Mini-Organ Extension/Kitchen Timer.

E92, December 1982
 Triode/Precision Power Supply/The XL System/Crescendo/Home Telephone Help/Soft Switching in-car Interfer/floppy Disc Interface for the Junior Part II/A Dozen and One Sounds (Stop-signal Override for Model Railways).

E93, January 1983
 The Elektor Music Synthesizer (10) - a,b,f,a.

E94, February 1983
 The Elektor Music Synthesizer (11) - a,b,f,a.

Back numbers of Elektor currently available are detailed above, with a brief description of their contents. Send for your copies now, using the pre-paid Order Card inside the back cover of this issue.

Prices are as follows: any one issue (except July/August) £ 1.20
 additional issues, each £ 1.00
 July/August (Summer Circuits) £ 2.40

Prices include postage and packing. Overseas orders requiring airmail postage add £ 1.50 per issue (£ 2.00 for July/August issue)

Volume purchase from Acorn brings massive savings for you!

Now only
£99 plus VAT

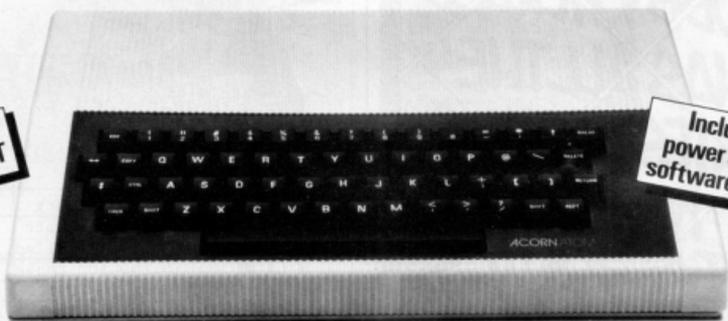

Includes free
power supply and
software worth £20

Cash in on our misfortune! Over £50 off an Atom Microcomputer

We recently made a bulk purchase of over 800 Acorn Atoms for sale overseas. The deal fell through! We are now offering those Atoms to you at the price we paid for them.

The Atom normally retails at £174.50 inc. VAT we are offering it to you at a mail order price of only £115 inc. VAT - an incredible saving of £59.50 plus a free power supply and software worth over £20.

The Computer

The Atom has 2K of RAM and 8K of ROM but of course this can be boosted enormously.

The computer has a full sized keyboard laid out in a conventional way. To use it just connect the power supply and a cable into the aerial socket of a TV set.

As well as integral sound output and direct cassette and TV interface, a wide range of additional interface boards are available to fit inside the casing. Extra 64K RAM, Colour, Printer, Laboratory, Cassette, 6522, 80x25 VDU, Analogue, Econet etc etc allowing the user to build a very sophisticated application machine. Full details of all accessories, disc pack, software etc are supplied with each machine.

The language used by the ATOM is BASIC, the language used by most personal computers.

The Atom's version is very fast, making it ideal for real time applications.

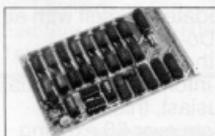

Expansion Cards



Plotting + Graphics



Word Processing



Real time applications

It has all the normal functions you would expect plus many powerful extensions making it very easy for you to operate and write your own programs.

The Atom is fully guaranteed. There are 80 nationwide authorised service centres. Just clip the coupon below or ring 01-930 1612 with your credit card number. Computer Marketplace Ltd, 20 Orange Street, London WC2H 7ED

To: Computer Marketplace Ltd, 20 Orange Street, London WC2H 7ED

Please send me ____ (qty) Acorn Atoms at £115 including p&p/pins.

Total £ _____

I enclose my cheque.

Please debit my Access/Barclaycard

Block Letters Please

NAME: _____

ADDRESS: _____

SIGNATURE: _____ E4

selektor

The potential of the bucket brigade

Charge-coupled devices, or CCDs as they are usually called, have evolved through semiconductor technology. Electronics engineers and technicians often think of them as 'bucket-brigade' elements in a circuit, from the way they work. But CCDs are making a remarkable contribution to such highly sophisticated fields as astronomy and particle physics. Because they are semiconductor devices, CCDs are robust, consume little power, have a long life and are compact. The unit of length used in describing them is the micrometre, and the extremely small dimensions must be remembered when looking at explanatory diagrams which have to be drawn large. Discussions range round charges of, say, only a thousand or so electrons, whereas a normal n -type doped silicon has some 10^{12} electrons per cubic millimetre. With CCDs we are in a minute world of microscopic size. Indeed, devices can have hundreds of thousands of unit cells on a chip hardly more than a square centimetre in area.

Furthermore, the manufacturing technology is simpler than that for integrated circuits, because it involves very few successive stages. It is based largely on well-known techniques used in making field-effect transistors. The basic, simplified CCD is outlined in figure 1, where (a) represents two CCD units, A and B. There is a charge of electrons in A. If the voltage on A is reduced to nothing and that on B is raised, the electrons travel through the n -type channel towards B. In this way the charge is 'coupled' or transferred between A and B. Part (b) is a somewhat more realistic side-elevation, showing the silicon p -type substrate (which has a deficit of electrons) on the top of which is a very thin n -type layer. Over this is an insulation layer of silicon dioxide. Above them all there are the conducting electrodes, which overlap but are insulated from one another. Depending on the purpose of the device, the thickness of the substrate may be from 35 to 300 μm and the n -type layer may be only a few micrometres thick.

The first, essential point to be understood is that the doped layers are depleted for use in CCDs. That is to say, they are deprived of mobile carriers, which are electrons in the n -type and 'holes', or electron deficits, in the p -type. This is done by applying a reverse bias, or

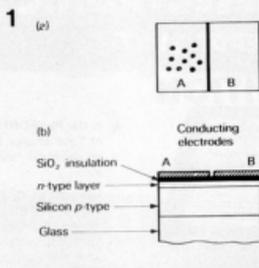

Figure 1. Elementary idea of two charge elements coupled together via the n -type channel and controlled by voltages at A and B in sequence (see text).

opposing potential, of about 20 V. It ensures that the n -type layer has plenty of space for electrons, often described as a conducting layer or channel. The depleted p -type layer is left negatively charged to a small depth, keeping electrons up into the channel.

The arrangement shown is not of any practical use, for alternation of the voltages on A and B would merely keep the charges going backwards and forwards between them. However, a linear arrangement of a number of elements could be useful if we can have a way of getting the voltages on the electrodes in the correct sequence. This is done by what is called a three-phase system. If we assume a charge of electrons under A (figure 2) and that the potential ϕ_1 is reduced to zero while ϕ_2 is given a voltage, then the charge moves from A to B, ϕ_3 also being zero. Next, ϕ_2 is reduced to zero and ϕ_3 given a voltage, and the charge moves to C. Next, ϕ_3 goes to zero and ϕ_1 is given a voltage. The charge moves to D. So the correct sequence of voltages in time makes the charge move along, eventually reaching J, where it goes to an amplifier and so forth. Obviously, there has to be a clocked sequence of voltages in the right order. It is obvious, too, that there is never a condition where there are two or three charges

contiguous.

The array so far considered is a *linear* one. It can be used in analogue mode, with each charge differing, or digital mode with individual charges representing 1 or 0. It can operate as a shift register, a serial-access store in computers, a delay line in telecommunications and television circuits and even, suitably modified, as a band-pass filter. It has been used for aerial surveillance and in other practical gear.

But what has put the CCD into the frontier of several fields of scientific research and development in the last few years is the idea of making it into a two-dimensional array, an area rather than a line. The reason lies in the fact that charges can be created in several ways. In the linear device, the first charge usually comes from preceding circuits and at exit goes into another circuit. However, when light enters silicon it creates charges by photoelectric effect, and the spectral range of sensitivity is quite wide. Also, if a high-energy particle enters an element of a CCD array it creates a charge by ionization. For these kinds of charge-creation the electrodes have to be transparent, which is arranged by making them of very highly doped silicon or of polycrystalline silicon instead of metal; they conduct well enough.

Area Array

If we imagine the linear array of figure 2 to be up-ended, with A at the top, and turned to show the electrode faces, and then add similar arrays side by side, we get the idea of an area array (except that, of course, the whole area is formed on one silicon chip). In addition, in order to restrain the electrons from moving sideways (that is, in the direction of the conventional x -axis in our imagined picture), so-called channel stops are formed from top to bottom after every three elements. Each stop is an extremely shallow channel and consists of very heavily doped p -type silicon; when depleted, it becomes a strong, negatively-

Figure 2. Linear arrangement of a CCD. Charge is moved along one element at a time from left to right. (Overlaps of electrodes are omitted for clarity.)

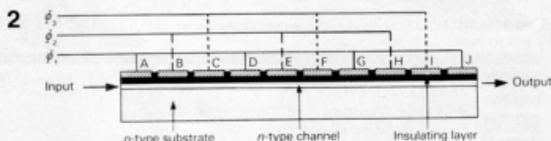

charged barrier. A picture-element, or pixel as it is known, then consists of an area covering three CCD elements horizontally and vertically. Obviously, the charges in each pixel cannot be seen. They are transferred, one row at a time, (in a so-called frame-transfer technique, which is not the only way) to a linear shift register with its own three-phase clock-pulse supply, so that each pixel charge is transferred individually into circuitry that includes micro-processors: the Cartesian co-ordinates and the size of the charge in each pixel are stored and transferred to a television screen or visual display unit (VDU), on which we can see the picture of how the original light or ionization is disposed, just as if the area CCD array were a photographic plate.

The advantage of such a CCD image sensor for astronomy has been described by one scientist for the UK Science and Engineering Research Council in quite unscientific terms: he says the sensitivity is "staggering". One sensor having 576 x 385 pixels in a surface of about 15 mm x 9 mm is in use at the Royal Observatory, Edinburgh. A CCD sensor has been commissioned for the Anglo-Australian telescope and yet another for the South African Astronomical Observatory. Stars and galaxies extremely difficult or impossible to photograph even with hours of exposure can now be recorded in minutes.

The need in high-energy physics is quite different. As everyone now knows, many particles have been identified and given strange names, with properties such as 'beauty' and 'charm'. Most of them have lifetimes expressible only with the help of

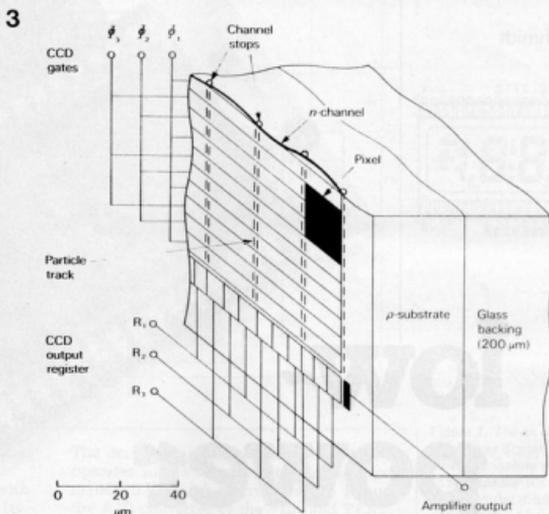

Figure 3. Area array with channel stops to restrain lateral movement of electrons. The pixel, or picture element consists of three CCD elements horizontally and vertically.

large negative indices, for example 10^{-12} seconds, so measuring them and their interactions has become more and more exacting. To do the job, highly-sophisticated pieces of apparatus such as the bubble chamber have been devised. Now, with the high sensitivity and resolution of CCD image sensors, together with the easy processing of the results by computers, physicists have yet another refined tool to use.

One experiment with four sensors

is shown in figure 4. An energetic particle hits a target, T. At one collision it causes the emission of particles with tracks P_1 and P_2 . Then, perhaps a couple of millimetres further on, it has another collision that gives rise to particle tracks Q_1 and Q_2 . Ordinarily it would be impossible to differentiate between the P s and Q s but with a CCD technique it should be possible to measure what happens with a precision of a few micrometres.

C.L. Boltz, *Spectrum 182*.

Figure 4. Four CCD plates arranged to detect secondary particles from the collision at Q.

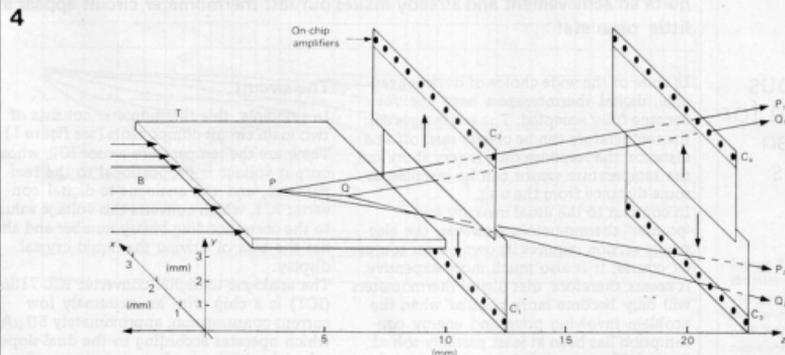

E. Schmidt

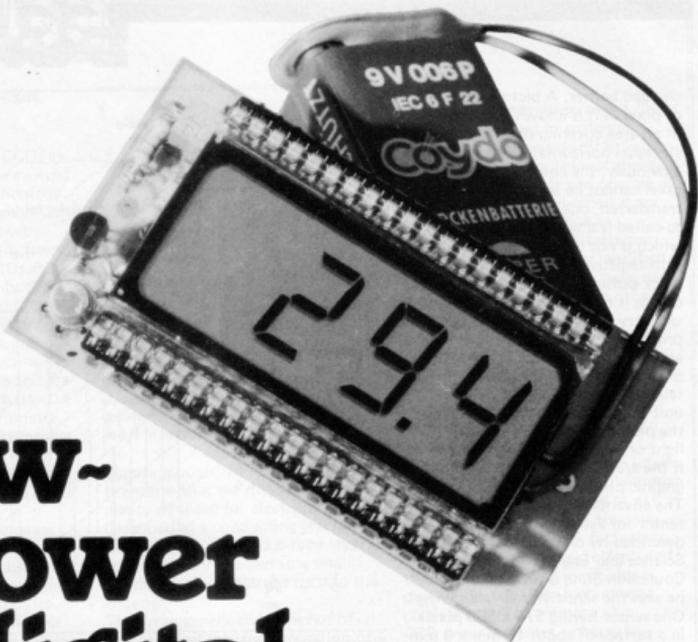

low- power digital thermometer

A large number of digital thermometers are available at present. Elektor has also kept up with the trend and published a standard digital thermometer with liquid crystal display in the October 1982 issue. Why is it that only a few months later we are coming out with a successor to the circuit already published? The thermometer described in this article can be operated continuously for more than six months without changing the battery. That is quite an achievement and already makes our last thermometer circuit appear a little obsolete!

continuous
operation for
more than
6 months

In spite of the wide choice of devices available, digital thermometers have not yet become fully accepted. The advantages are: the temperature can be clearly read off at a distance; the response time is very short and the temperature sensor can be installed at some distance from the unit. In contrast to the usual mercury and 'pointer' thermometers, however, the electronic version requires its own power source. Of course, it is also much more expensive. It seems, therefore, that digital thermometers will only become more popular when the problem involving price and energy consumption has been at least partially solved. Special ICs are needed for this type of circuit, but the investment is worthwhile.

The circuit

In principle, this thermometer consists of two main circuit components (see figure 1). These are the temperature sensor IC2, whose output voltage is proportional to the temperature, and the analogue-to-digital converter IC1, which converts this voltage value to the corresponding binary number and also has the task of driving the liquid crystal display.

The analogue-to-digital converter ICL 7136 (IC1) is a chip with an extremely low current consumption, approximately 50 μ A, which operates according to the dual-slope principle. With a reference voltage of 100 mV which must be applied to it

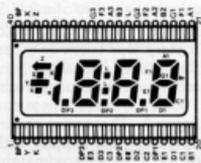
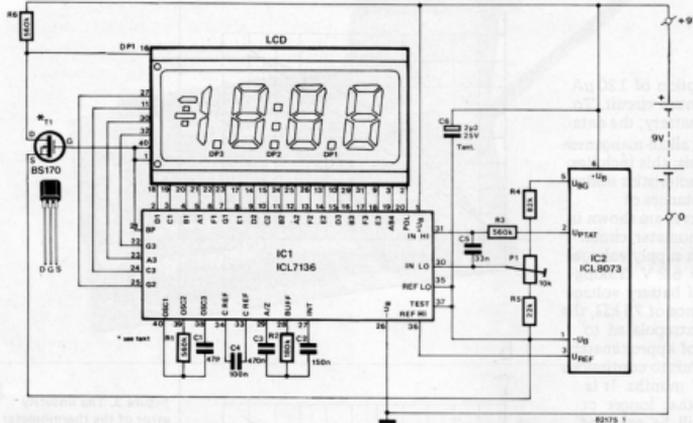

between REF_{LO} and REF_{HI} , its measuring range is then ± 199.9 mV.

Thus the converter directly indicates with proper polarity the voltage applied to its inputs IN_{LO} and IN_{HI} . The sign is positive if the potential applied to IN_{HI} is higher than that at IN_{LO} ; in the inverse case, a "-" appears on the display. The frequency of the internal oscillator is adjusted with external components C1 and R1. At the specified values, a clock frequency of approximately 16 kHz is obtained; this means that the ICL 7136 executes approximately one conversion per second. Polycarbonate or polyester capacitors should be chosen for C1, C3 and C4 to keep the measuring error of the A/D converter less than 0.1°C (0.1°C corresponds to 1 LSB). The backplane signal must be inverted to generate the decimal point. This is performed with transistor T1 and resistor R6. An alternative is to utilise a BC 549C with a 4M7 base resistor.

The temperature sensor ICL 8073 (IC2) operates with a supply voltage of approximately 5 V which is presented to it by the A/D converter at the $+U_B$ and TEST terminals. The 100 mV reference voltage for the A/D converter is presented by the sensor between U_{REF} and $-U_B$. The 1 mV/K voltage which is proportional to the temperature (with respect to $-U_B$) is generated at UPTAT. This signal is applied to the measuring input of the A/D converter via a lowpass network consisting of R3 and C5. At 0°C (corresponding to 273 K), therefore, an output voltage of 273 mV is present. As already mentioned, the difference voltage between IN_{HI} and IN_{LO} is indicated by the A/D converter. Thus a voltage of 273 mV must be presented to the IN_{LO} input in order for the LCD to display the value '0' at 0°C. This is achieved by dividing down the reference voltage U_{BG} (approximately 1.23 V) via potential divider R4, P1, R5 and

Figure 1. The circuit of the low-power digital thermometer mainly consists of two special ICs and the liquid crystal display. IC2 operates as a temperature sensor. IC1 evaluates the voltages of IC2 and drives the LCD. The operating current drawn by the entire circuit does not exceed 150 μ A.

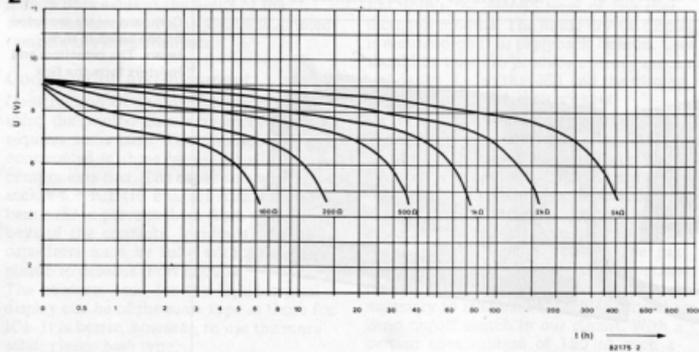

Figure 2. Typical characteristics of a 9 V alkaline-manganese battery. With a minimum battery voltage of 6.2 V and average load resistance of 75 k Ω , the operating time obtained is approximately 5400 hours!

by adjusting preset potentiometer P1 to obtain exactly 273 mV at IN_{LO}. The temperature sensor ICL 8073 draws a current of approximately 50 μ A.

Energy consumption

A typical current consumption of 120 μ A can be expected for the entire circuit. To calculate the life of a 9 V battery, the data sheet of the VARTA 4022 alkali-manganese battery was taken as a basis; this includes the typical discharge characteristics under continuous load using resistances of 100 Ω . . . 5 k Ω . These curves are shown in figure 2. The entire thermometer circuit operates quite happily with supply voltages of 12 V to approximately 6.2 V. Taking 6.2 V as the lower limit of battery voltage and an average load resistance of 75 k Ω , the group of curves can be extrapolated to obtain an operating time of approximately 5400 hours. This corresponds to continuous operation for more than 7 months. It is quite possible, however, that longer or shorter operating times will be achieved because the calculations relate to typical data for the discharge characteristic and current consumption of the temperature sensor and of the A/D converter. In general though, the typical data are met by approximately 50% of the components.

Precision

Linearity of the thermometer depends almost exclusively on the temperature sensor, because the specifications of the ICL7136 A/D converter are so good that its error contribution can be discounted. The ICL8073 temperature sensor can be procured in different classes of precision and specified temperature ranges. Its transfer characteristic has the form shown in figure 3a. The thermometer can be aligned at any temperature with preset potentiometer P1. The slope of the characteristic is needed to be able to calculate the measuring error in the region of this alignment point. In this case it is practical to replace the curve by a straight line as an approximation, as shown in figure 3a. After the 25°C alignment the ideal characteristic is shifted as shown in

3a

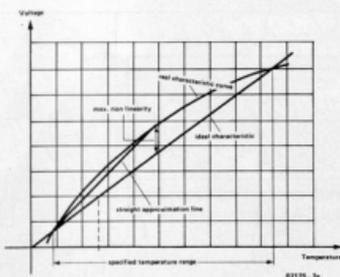

b

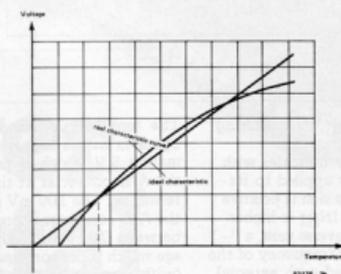
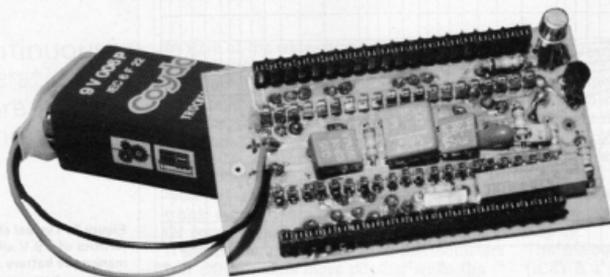

figure 3b. If one calculates the error of the lowcost ICL8073 JIUT sensor, whose specified maximum linearity error is $\pm 1.5^\circ\text{C}$ over the temperature range 0 . . . 70°C, the resultant maximum error is $\pm 0.2^\circ\text{C}$ over a range of $\pm 5^\circ\text{C}$ around the alignment point. The highgrade ICL8073 KIUT sensor would have a maximum error of $\pm 0.026^\circ\text{C}$ under the same conditions. A slight, additional measuring error is caused by the tolerance of the reference voltage presented to the A/D

low-power digital thermometer
elektor april 1983

Figure 3. The linearity error of the thermometer in the region of room temperature is best indicated by these characteristics. If, for example, alignment was performed at 25°C the resultant maximum error is $\pm 0.2^\circ\text{C}$ over a range of $\pm 5^\circ\text{C}$ around the alignment point (figure 3b). Figure 3a shows the real and ideal characteristics for the specified operating range. In the region of the alignment point, the characteristic curve is approximated by a straight line.

Components are mounted on the board in three layers. The capacitors and resistors form the first layer . . .



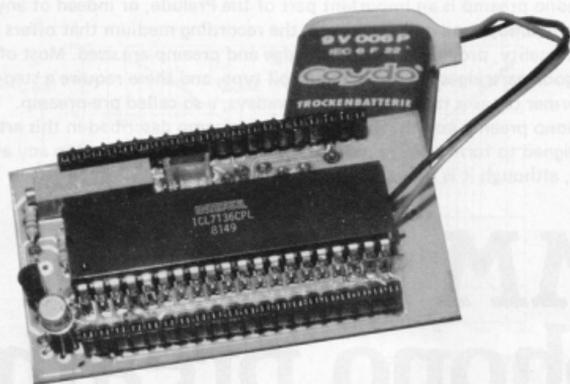

... and IC1 is mounted above them, as the second layer (using IC contact strips). The third layer is the LCD display, producing the final result on the first page of this article.

4

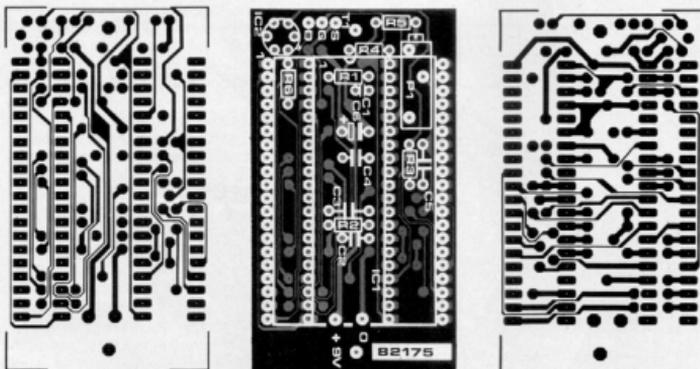

Figure 4. Track pattern and component overlay of the dual-clad, through-contacting thermometer p.c.b.. It is constructed in three levels. Care should be taken to produce a strong mechanical construction. As an option, the sensor can be directly inserted into the p.c.b..

Parts list

Resistors (1/8 W):

- R1, R3, R6 = 560 k
- R2 = 180 k
- R4 = 82 k
- R5 = 22 k
- P1 = 10 k preset (multiturn)

Capacitors (see text):

- C1 = 47 p
- C2 = 150 n
- C3 = 470 n
- C4 = 100 n
- C5 = 33 n
- C6 = 2µ/25 V tantalum

Semiconductors:

- T1 = BS 170 or BC 549C (see circuit description)
- IC1 = ICL 7136 (Intersil)
- IC2 = ICL 8073 JIUT (Intersil)

Miscellaneous:

- 9 V compact battery with terminals and leads
- 3½-digit liquid crystal display:
- Hitachi LS 007CC, H 1331C-L
- LXD 4305R03
- Hamlin 3901, 3902
- Norsmen NDP
- 530-035A S-RF-P1

converter by the sensor; its value should be exactly 100 mV. However, this error is mainly noticeable at the limits of the measuring range and is negligible in ambient temperature measurements.

Construction and alignment

Construction of the digital thermometer using the printed circuit board of figure 4 requires some care. The thermometer is constructed in three levels. Fit all passive components first. The capacitors within the socket for IC1 (IC contact strips) must be bent over to prevent them from protruding beyond the contacts. Incidentally, these capacitors must be fully encapsulated in plastic to prevent short-circuits.

The contacts used for the liquid crystal display can be of the same type as those for IC1. It is better, however, to use the more solid, plastic-base type.

The temperature sensor IC2 can be directly inserted into the p.c.b. or solder pins can be

inserted in its place, to allow its connecting leads to be soldered on later.

IC1 forms the second level of the thermometer module. The liquid crystal display is mounted on it in piggyback fashion. Care should be taken to produce a strong mechanical design, i.e. so that IC1 and the display are firmly seated in their sockets.

Since the thermometer is particularly suitable for measuring room temperature, on account of the sensor used, the 'comparison method' is utilised for simple alignment. In the Elektor laboratory a standard alcohol thermometer was used as a reference. P1 is adjusted to obtain its value on the LCD. An occasional comparison between the two readings indicates whether the low-power digital thermometer is accurate. It may be necessary to readjust P1. Incidentally, there is no on/off switch in our circuit. With a current consumption of 150 µA such a switch seemed an unnecessary luxury!

The phono preamp is an important part of the Prelude, or indeed of any audio system. Gramophone records are still the recording medium that offers the highest quality, provided a good cartridge and preamp are used. Most of the really good cartridges are the moving coil type, and these require a step-up transformer or, as is more common nowadays, a so-called pre-preamp. The phono preamp and the moving coil pre-preamp described in this article are designed to form a single module. This can be incorporated in any audio system, although it is intended as part of the Prelude.

MC/MM phono preamp

100 μV in,
100 mV out

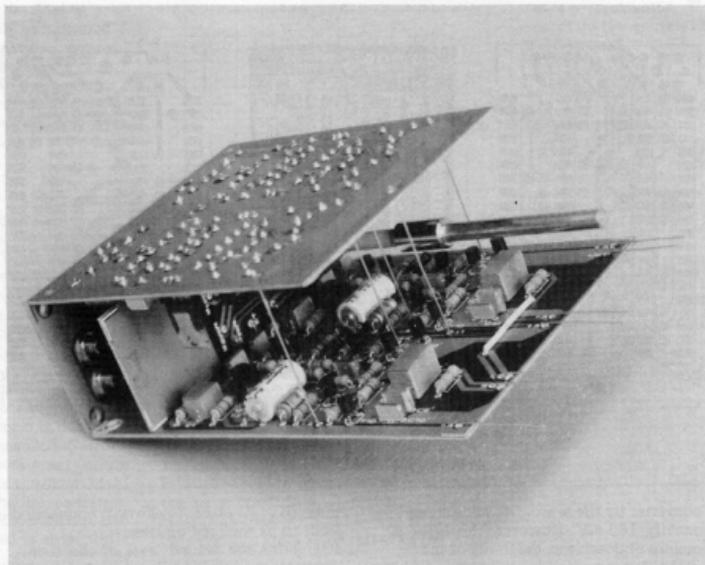

Photo. The complete MC/MM phono preamp module. Once all the connecting wires are in position, it is a fairly rigid construction.

A phono preamp must do two jobs. It must boost the output from a moving magnet (or 'dynamic') cartridge to a sufficient level, and it must modify the frequency characteristic in a precisely-defined way. Figure 1 shows the theoretical recording characteristic as a set of bold straight lines, running from lower left to upper right; the thin line running through these is the actual characteristic. To achieve a flat overall response, the inverse characteristic must be applied during playback; this is the thin line running from upper left to lower right in figure 1. Achieving this type of characteristic may seem quite a feat, but in fact it is mainly a question of ensuring that a set of normalised RC time constants are included in the preamp. For once, the Americans agree with us: their RIAA response corresponds to the

European IEC specification. Reading from left to right in figure 1, the first time constant is 3180 μs : this causes the response to fall at 6 dB/octave from about 50 Hz. Then we come to 318 μs - this tends to flatten out the response above 500 Hz - almost immediately followed by 75 μs , which leads to a further 6 dB/octave slope above 2120 Hz.

Knowing what time constants are required is one thing; knowing where to insert them in the circuit is another. There are two basic possibilities: you can either use passive RC networks, or you can include them in a feedback loop to obtain active filters. Obviously, since there are three time constants to be included, you can also include one or two as passive networks and the rest as an active network. Some of the possi-

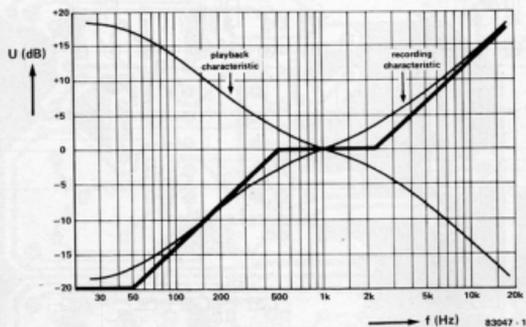

Figure 1. The frequency characteristic used when cutting a record (lower left to upper right), and the response required during reproduction (upper left to lower right).

bilities are illustrated in figure 2.

A passive filter can be mounted at the preamp input, as shown in figure 2a. This has the disadvantage that the signal level is drastically reduced at high frequencies (-30 dB or so!) before it reaches the input stage. This is asking for a poor signal-to-noise ratio.

So, try it the other way: mount the RC networks at the output, as shown in figure 2b. Now we run into a new problem: the input signal is at such a level that it will not only mask the noise, but there is a good chance that it will drive the preamp into distortion! The most common approach is shown in figure 2c. The RC networks are included in the feedback loop. Provided the circuit is properly designed, this can give quite good results. However, the system shown in figure 2d is even better: the two lower time constants are included in the feedback loop, so that there is little risk of overloading the preamp. The third RC network, however, is included as a passive filter at the output. This means that the higher frequencies are passed through the preamp at relatively higher levels, thus improving the overall signal-to-noise ratio. As an added bonus, this system makes it slightly easier to design a good preamp: rolling off the frequency response of an amplifier towards higher frequencies tends to lead to instability!

Reading between the lines in the last paragraph, it will be obvious that the circuit described here corresponds to figure 2d.

The moving-magnet preamp

The right-hand section of figure 3 should by now be familiar: basically, it is the 'discrete opamp' that is used throughout the Prelude. The circuit was discussed at length in the articles on the headphone amplifier and the line amplifier, so there is little point in repeating the whole story here.

In a nutshell: the input stage is a differential amplifier (T1, T2) with a current source in the commoned emitter line (T3). The collector output currents are combined by

2

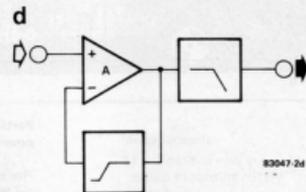
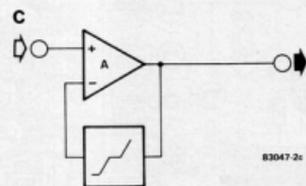
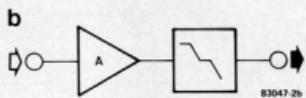
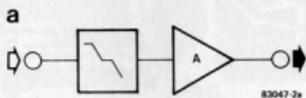

Figure 2. The official time constants can be included in the preamp in several ways. Purely passive networks can be used, either preceding (2a) or following (2b) the preamp; or the networks can be included in the feedback loop (2c). The solution shown in figure 2d (two time constants in the feedback loop and one as a passive network at the output) gets the best of both worlds.

3

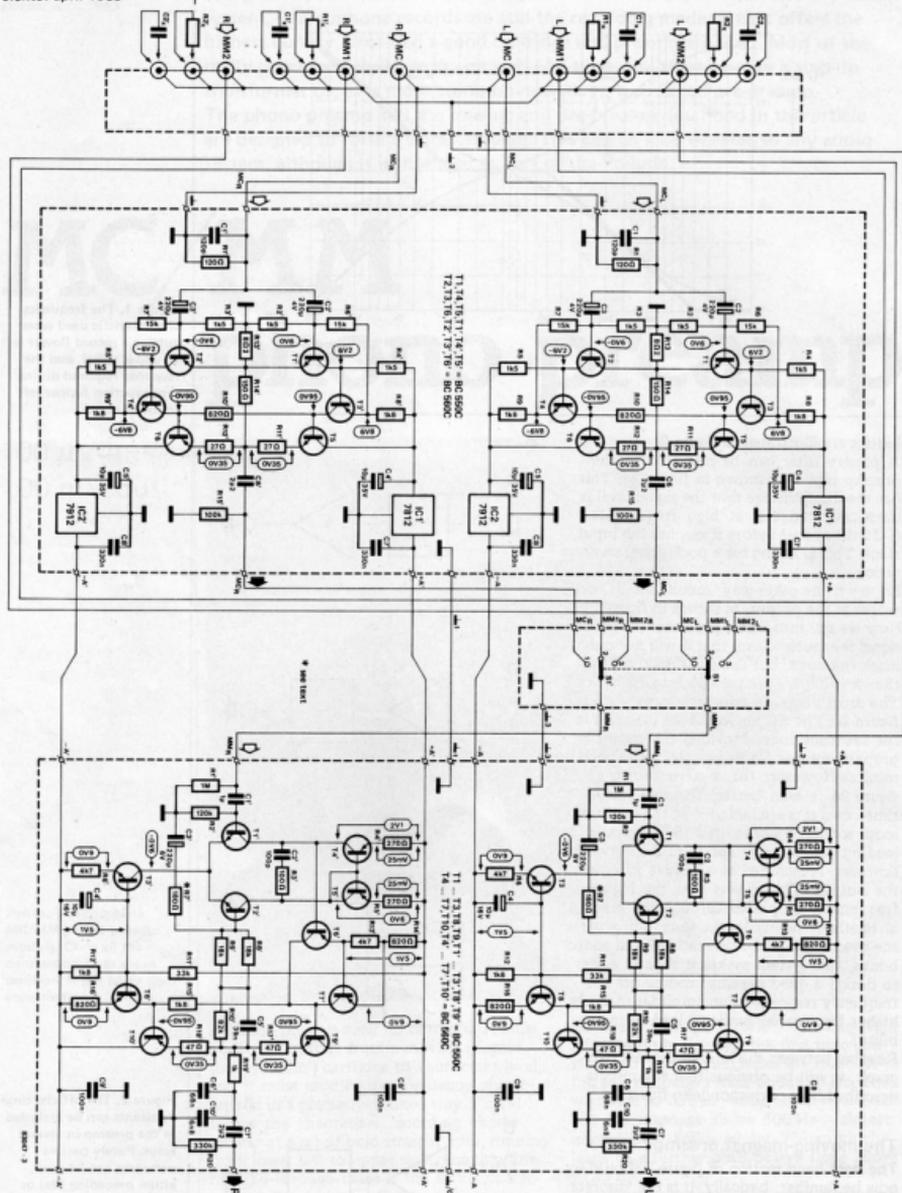

Figure 3. The complete circuit, with moving coil pre-amp and moving magnet pre-amp. Additional input sockets are provided, so that the input impedance can be tailored to suit any particular cartridge.

Parts list for MC pre-
 preamp

Resistors:

- R1, R1' = 120 Ω
- R2 ... R5,
- R6, R6', R7, R7' = 15 k

- R8, R8', R9, R9' = 1k8
- R10, R10' = 820 Ω
- R11, R11', R12,
- R12' = 27 Ω
- R13, R13' = 8k2
- R14, R14' = 150 Ω
- R15, R15' = 100 k

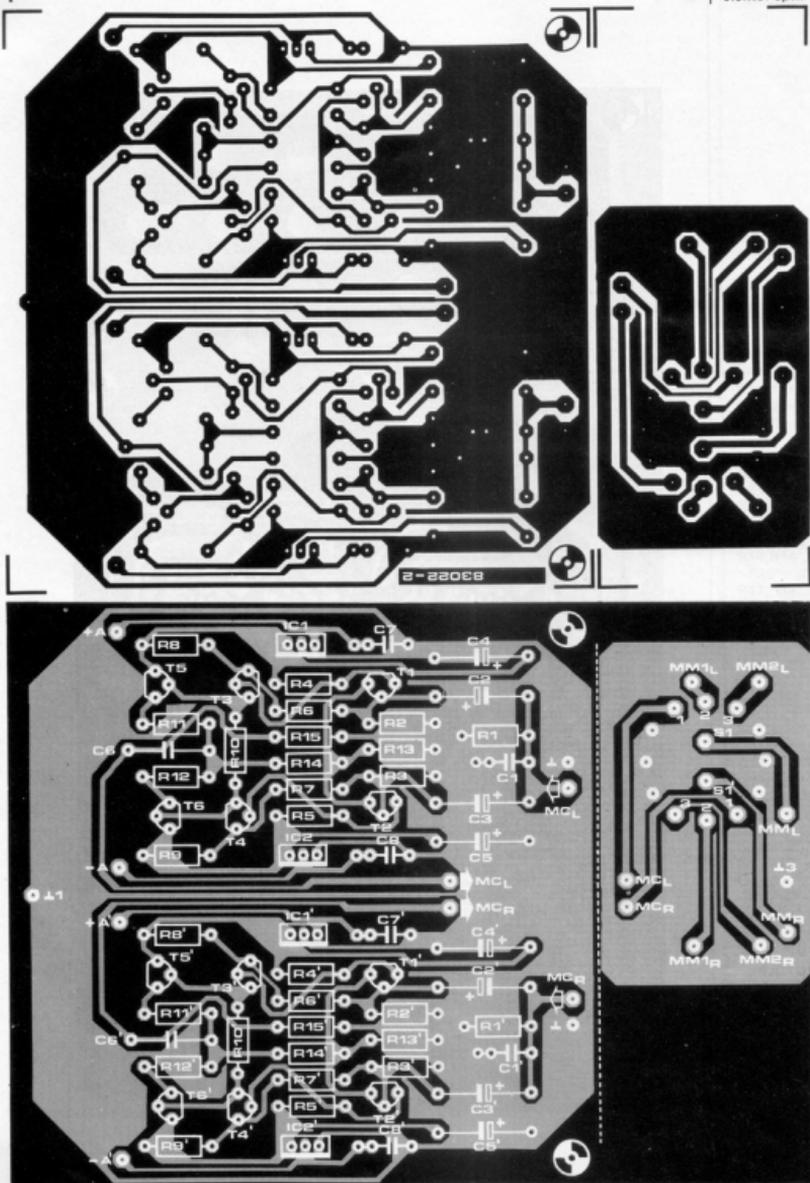

Capacitors:

C1, C1' = 120 p
 C2, C2', C3, C3' = 220 μ /4 V
 C4, C4', C5, C5' = 10 μ /35 V
 C6, C6' = 2 μ 2
 C7, C7', C8, C8' = 330 n

Semiconductors:

T1, T1', T4, T4', T5,
 T5' = BC 550C
 T2, T2', T3, T3', T6,
 T6' = BC 560C
 IC1, IC1' = 7812 (5%)
 IC2, IC2' = 7912 (5%)

Miscellaneous:

S1 = 2-pole, 3-way p.c.-
 board mounting rotary
 switch
 extension spindle for
 S1, with front-panel
 mounting bearing

Figure 4. This board actually consists of two parts that must be separated. The larger section is for the moving coil pre-preamp; the smaller piece is for mounting the input selector switch.

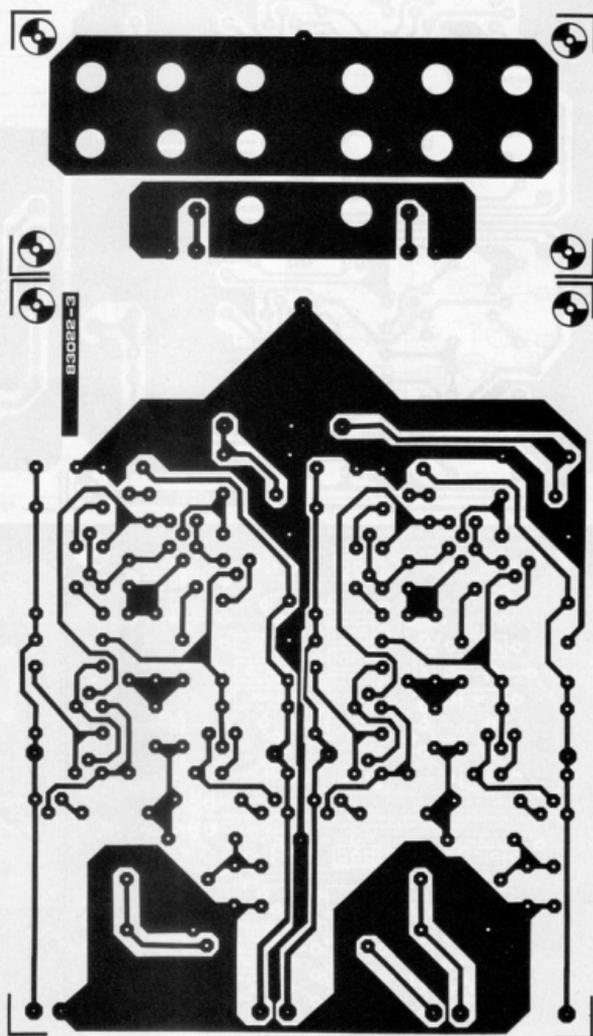
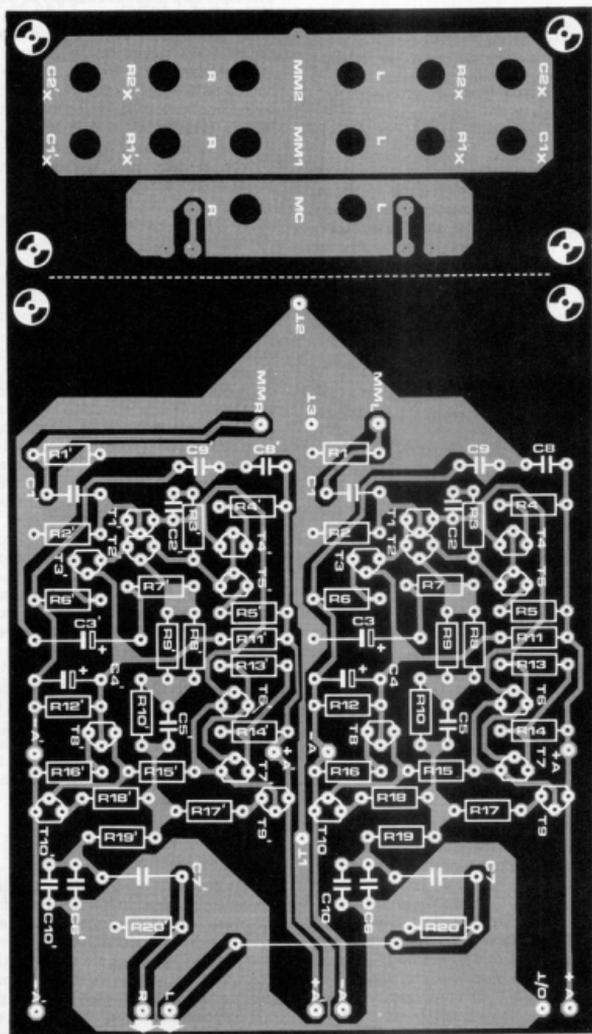

Figure 5. The p.c. board for the moving magnet preamp and that for the cinch input sockets. These boards must be separated before mounting any components.

means of a current mirror (T4, T5) and passed via a Darlington stage (T6, T7) with a current source as collector load impedance (T8) to the class-A output stage (T9, T10). The feedback loop (C5, R7... R10 and C3) includes the first two time constants, as

explained above. This means that the response is flat above about 500 Hz, with a gain of 50 set by the ratio of R8/R9 to R7. From 500 Hz down to 50 Hz, the response rises at 6 dB/octave; below 50 Hz, the gain is again constant (500, set by the ratio of



Parts list MM preamp

- Resistors:
 R1, R1' = 1 M
 R2, R2' = 120 k
 R3, R3' = 100 Ω
 R4, R4', R5, R5' = 270 Ω
 R6, R6', R13, R13' = 4k7
 R7, R7' = 180 Ω
 R8, R8', R9, R9' = 18 k
 R10, R10' = 82 k
 R11, R11' = 33 k
 R12, R12', R15, R15' = 1k8
 R14, R14', R16, R16' = 820 Ω
 R17, R17', R18, R18' = 47 Ω
 R19, R19' = 1 k
 R20, R20' = 330 k
 R1x, R1x', R2x, R2x' = see text

- Capacitors:
 C1, C1' = 1 μ
 C2, C2' = 100 p
 C3, C3' = 220 μ /6 V
 C4, C4' = 10 μ /16 V
 C5, C5' = 39 n
 C6, C6' = 68 n
 C7, C7' = 2u2
 C8, C8', C9, C9' = 100 n
 C10, C10' = 6n8
 C1x, C1x', C2x, C2x' = see text

- Semiconductors:
 T1, T1', T2, T2', T3, T3', T8, T8', T9, T9' = BC 550C
 T4, T4', T5, T5', T6, T6', T7, T7', T10, T10' = BC 560C

- Miscellaneous:
 14 metal cinch sockets, screw-mounting
 8 cinch plugs for R_x and C_x

R8//R9 + R10 to R7). The third time constant, causing the response to roll off above 2120 Hz, is the passive output network (R19, C6 and C10).

There are three inputs, selected by means of S1: the moving coil pre-amp and two

moving magnet inputs. These are shown at the left in figure 3. There are actually three sockets for each of these inputs: one for the signal input, and two for impedance matching (R_x and C_x). This is explained in detail in a separate article ('RC equalizer'), elsewhere

in this issue. Note that the basic input impedance of the preamp is 107 k ($R1/R2$), so that four 82 k resistors must be inserted in the R_x positions to obtain the 'standard' 47 k input impedance.

The moving-coil preamp

Moving coil cartridges give a beautifully 'clean' signal, but at a very low level (100... 500 μ V). This means that a 'pre-preamp' must be included between the cartridge and the 'normal' moving magnet preamp.

The pre-preamp is the left-hand section in figure 3. It is a fairly simple-looking circuit, but it is designed for extremely high performance – in particular, the signal-to-noise ratio must be exceptional in this application. A fully-complementary class-A design is used. T1... T4 give high gain, and T5 and T6 are the output drivers. The gain is set by R14 and R13 in the feedback loop; very low values are used to obtain an extremely low input noise figure. The gain of this pre-preamp is 20; overall, from MC input to phono preamp output, this means that the gain is 1000. In other words, 100 μ V in will give 100 mV out.

The DC setting is determined by R2, R3, R6 and R7; the current through the input devices is determined by R4 and R5. This means that anyone who feels like experimenting with different input transistors can easily set the optimum collector current by modifying these two resistors.

The positive and negative supplies are derived from the main +15 and -15 V rails. Integrated 12 V regulators are included, mainly to ensure that no hum, noise, interference spikes or whatever can possibly reach the pre-preamp.

The input impedance is approximately 100 Ω : suitable for practically all moving coil cartridges. If an even lower impedance is desired, the value of R1 (and R1') should be reduced accordingly.

Construction

Although the moving-magnet preamp and the moving-coil pre-preamp are both complete units that can be used separately, we will only discuss the construction of the complete phono input module – using both, in other words. Even if the pre-preamp is not (yet) needed, it is best to use both boards to obtain a reliable electrical and mechanical construction. No components need be mounted on the second board in that case.

As can be seen in figures 4 and 5, both boards consist of two sections. Before doing anything else, these must be separated. The small piece from the moving-magnet board is intended for cinch-type input sockets; the piece that is cut off the other board is used to mount the input selector switch.

As usual, good quality components should be used; R7... R10, C5 and C6 should be 5% types or better. When all four boards are complete, the one with the input sockets is mounted at right-angles at one end of the moving-coil board (on the component side

near the electrolytics) with the connections MCL, \perp , MCR and \perp mating correctly. These four connections run from the track side of the cinch board to the component side of the moving-coil board.

The next step is to mount a set of connection wires. The four sets of three cinch plugs must be interconnected, if this was not done earlier, and a longish lead is soldered to the \perp connection on the free edge of the cinch board (on the track side). Four wires (4 or 5 cm long) are soldered to connections MM1L, MM1R, MM2L and MM2R on the selector switch board, again leading back from the copper track side. Two shorter sections (2 cm or so) are connected to MCL and MCR on one long edge of this board, and another pair to points MML and MMR on the opposite edge.

Having done all this groundwork, it is a good idea to compare all the bits with the photo of our prototype. When the MCL and MCR leads from the selector switch board are mated to the corresponding points on the moving-coil board, the four long leads from the switch board should reach easily to the cinch connectors. Note that the indications near the leads correspond to the four sockets that they must connect to. These leads can now be shortened to length and soldered to the sockets. Next, the moving-magnet board can be mounted (component side facing in); this involves two leads from the selector switch board and one from the input sockets. Finally, five interconnections are made between the two preamp boards – note that they all run straight across.

The completed module can now be mounted on the Prelude bus board. Unless you are very lucky, the switch shaft will have to be extended. If the rest of the modules are also in position, including the tone control unit described this month, you can proceed to the first test. With either of the MM inputs selected, no noise should be audible; for the MC input, a faint hiss may be audible with the volume control turned fully up. Not to worry: you'll have to turn the volume down again before putting on a record!

Input impedance matching

To get the best out of a dynamic (moving magnet) cartridge, the input impedance of the preamp must be properly matched. This is dealt with in greater detail elsewhere in this issue, but a few points are worth noting. The input impedance of this preamp is approximately 107 k, parallel to 25 pF. As a first approximation, as mentioned earlier, four 82 k resistors can be mounted in the R_x sockets. This brings the impedance down to 47 k. In practice, most cartridges tend to give best results when loaded with approximately 300... 500 pF; bearing in mind that the cable capacitance can be anything from 50 pF up to a few hundred pF, it is worth experimenting with several values for C_x (from zero up to about 470 pF), to see which gives the best results.

So much for the analogue section of the Prelude. All that remains for the next few issues are some final comments, practical tips, and the remote control unit. ■

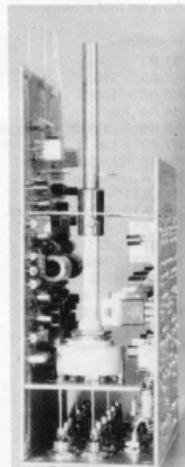

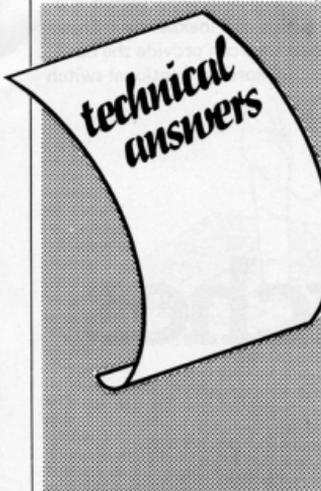

National filter with application fault

We are grateful to an observant reader for pointing out that the 'Applikator' in the September 1982 issue, concerning the National Semiconductor MF 10 filter module, contains a pretty silly mistake.

In figure 6, a Butterworth 4th order low-pass filter with a cutoff frequency of 2 kHz was assembled by connecting two 2nd order filters in series; each of these two filters also had a cutoff frequency of 2 kHz.

Of course, that simply will not work! When connecting filters in series, both the Q and the cutoff frequency of each individual filter must be determined, in accordance with the filter type. The correct filter data are specified in the figure.

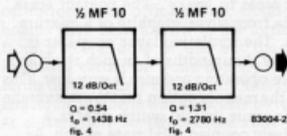

The result is that the simple circuit of figure 7 cannot be used. In order to achieve different cutoff frequencies for the two filter sections, at least one of them must be constructed according to figure 4; here the cutoff frequency not only depends on the clock frequency but also on the ratio R2:R4. Another possibility is to apply two different clock signals (corresponding to the desired filter cutoff frequencies) to the two clock inputs CLK_A and CLK_G in the circuit of figure 7.

Marking of digitast switches

Here is a tip from a reader: If the tops of digitast switches are marked

with transfer letters, the lettering soon wears off because of repeated finger pressure. However, these switches have an inclined surface at the front of the moving upper part. If this inclined surface is marked (character height 2.1 mm) the lettering is not subjected to wear.

In order to mark the fronts of digitast switches that have already been soldered in, there are two possibilities: the switch must either be unsoldered or the moving upper part must be separated from the lower soldered part of the digitast switch. The second possibility can be implemented quite simply by pressing the upper half of the switch first backwards and then gently upwards. The upper part then jumps out. To insert it again, only a slight pressure from above is required to engage the upper part once more.



Slave flashgun powered by the mains

There is a requirement for a slave flashgun for taking a series of pictures indoors without the inconvenience of rechargeable or disposable batteries. Powering the unit from the mains would enable it to be used at any time. But why follow the usual procedure of mains voltage – low voltage – high voltage? A reader points out that it should be possible to use the mains directly without a transformer. Of

course he is right. The only problem is that particular attention must be paid to electrical safety because of the lack of isolation from the mains. It did not take long to design the circuit. We have not yet tested it, but the circuit has been assembled from well-proven circuitry including the 'Slave flash trigger' described in the 1982 Summer Circuits issue. The flash tube and ignition transformer are available by mail order and from some electronic component shops. The sensitivity greatly depends on the size of solar cells SZ1 and SZ2. When switch S1 is closed the flash energy is doubled. The 100 ohm resistor in the lead limits the charging current to values which are suitable for electrolytic capacitors and the mains.

Crescendo coils and S/N ratio

Some questions were raised regarding winding of the 2 x 10 turns of coil L1 in the Crescendo power amplifier. This is clarified in the drawing.

Readers have also pointed out that the signal-to-noise ratio is missing from the 'Technical Data'. There is not much that can be measured; with no signal applied to the input, the output is absolutely quiet. Expressed in decibels, the figure is: SNR greater than 110 dB, referred to rated power.

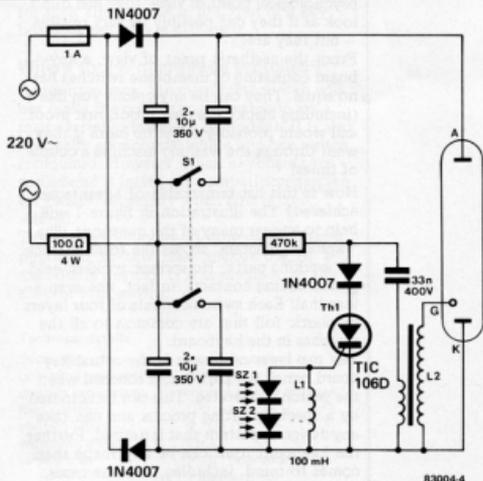
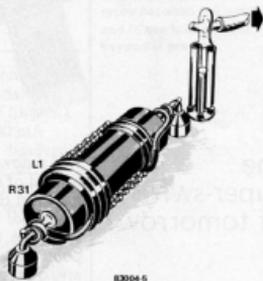

The membrane switch — or foil switch as it is becoming popularly known — is almost too good to be true. The switch is both reliable and inexpensive. These two factors coupled with its 'science fiction' appearance can provide the basis for a very elegant and economical keyboard that the more conventional switch cannot hope to match.

membrane switches



the
super-switch
of tomorrow?

If Asimov had been a hardware designer instead of a science fiction writer we would have had the membrane switch about twenty years ago! They really do have the aura of space-age technology. The most striking point about them is their appearance, they are, quite literally, wafer thin. This fact, paradoxically, is a disadvantage from the psychological point of view, they just don't look as if they can possibly be very reliable — but they are!

From the aesthetic point of view, a keyboard consisting of membrane switches has no equal. They can be any colour you like (including black), are dust proof, rust proof and would probably suffer no harm if they went through the washing machine a couple of times!

How is this list remarkable of advantages achieved? The illustration in figure 1 will help to answer many of the questions. The 'exploded diagram' shows the total absence of 'working parts'. No springs, rockers, gold plated sliding contacts, in fact, not even a terminal! Each switch consists of four layers of plastic foil that are common to all the switches in the keyboard.

The top layer of plastic is the actual keyboard panel, the part that is touched when the switch is operated. This can be coloured by a special printing process and can take any design or pattern that is desired. Further, the keyboard itself can be any shape that comes to mind, including, in some cases, bending round corners. We would like to see

the toggle switch that does that!

The switch contacts are carried on two layers of flexible plastic and these are separated by a third layer of polythene foil. This 'spacer' has holes or cutouts in it that coincide with the switch contact areas in the upper and lower foils. When the front panel, or 'keyboard', is pressed, the upper contact layer is locally distorted allowing the two contact areas to 'make'. The contact areas are made from silver, graphite or a mixture of both. The insulating layer or spacer is only a few thousandths of an inch thick and therefore operating pressure is very low. This creates the misconception that the membrane switch is a true 'touch' switch, that is, a capacitively coupled solid state switch. As we have seen, this is not the case.

The complete keyboard is connected to the outside world via a flexible connecting strip. This normally pushes into an edge connector on a printed circuit board but it can also be soldered directly onto a board if needed. However, soldering such a thin (plastic!) strip is fraught with much difficulty and is not encouraged.

Advantages

The manufacture of a keyboard consisting of membrane switches is very easy. It is also economical due to that fact that a number of keyboards can be printed on a single sheet and then cut out.

The operation of a switch is simple, a soft touch is all that is required. If necessary a

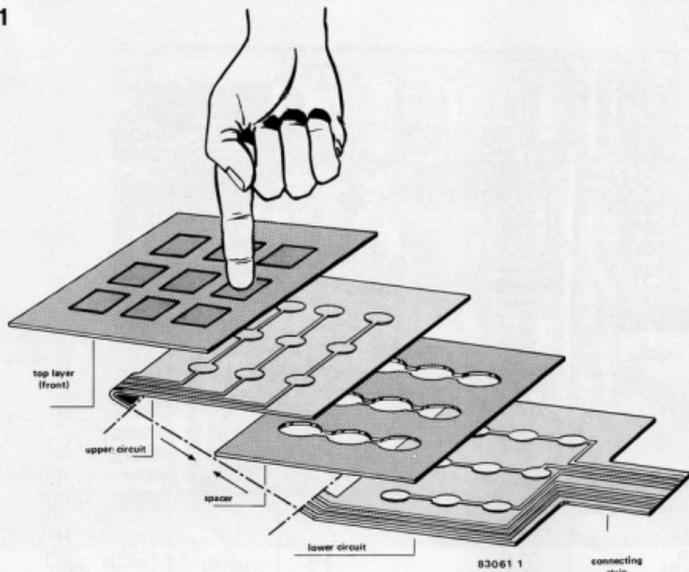

Figure 1. Membrane switches consist of four layers of plastic foil. The secret of the switch lies in the holes in the spacer. This is where contact is made between the upper and lower foils when a keypad is pressed.

light can be fitted behind the switch to show that it has been operated as anybody who has ordered a 'Big Mac' can recall.

The complete keyboard is entirely water and dust proof. Corrosion is also not a problem as very few chemical substances can attack the plastic foil used.

Mounting the keyboard is simplicity itself – it is usually backed with a self stick material and the whole keyboard is just placed on a sheet of aluminium and that is that!

As mentioned previously, shape can take many forms for any number of applications. This keyboard has no fear of that horror of horrors – the office coffee. Good keyboards have been known to die instantly from a liberal dose of this but the foil keyboard carries on quite happily. A good scrub down with a mixture of nitric acid and liquid methane will obviously be required at a later date to remove the stuff but operation is unimpaired.

Cost always rears its ugly head when anything good comes along but in this case there is a happy ending. The complete keyboard can be produced at a fraction of the cost of conventional keyboards.

What about long term reliability? With no moving parts what can go wrong? A persistently strong finger may make some impression after a hundred years or so but it is unlikely!

So we now have what appears to be the super switch of the century. Does it have no Achilles heel?

Disadvantages

If one is ill-advised enough to attempt to switch 10 amp loads with our switch it

reveals a marked tendency to get somewhat 'soggy' – in a very few microseconds! (It also creates severe bluntness of the fingers.) In all fairness, the restriction to 100 mA loads can not really be classed as a disadvantage as that is more than enough to carry out the purpose for which it was intended. Whether high current versions will eventually be produced is yet to be seen.

Switch configuration looms large on the disadvantage side of the fence. We have a choice – press to make – or nothing! Not even a single pole changeover. Here again, for their allotted task in life, that of a keyboard switch, this is sufficient.

Where to use membrane switches

As we have seen, the membrane switch will not make the conventional switch in its many varieties instantly redundant. It is also not really economical where just one switch is required. However, when keyboards are considered it leaves the competition gasping for breath, especially when cost is considered.

The Elektor 7-day multi-time switch that is published in this issue makes use of a membrane keypad. It is available from the Elektor ESS service.

Technical details

thickness:	approximately 1 mm
operating pressure:	1 – 2 N
contact separation:	approximately 0.2 mm
load current:	100 mA at 30 V
contact resistance:	< 100 Ω
switching time:	1 ms
service life:	> 10 ⁶ operations per contact
operational temperature:	-30°C to +65°C

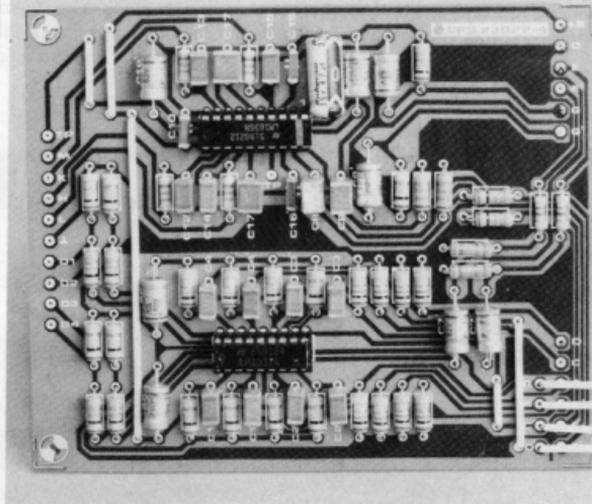

The convenience of remote-control for television sets is fairly well-known. The Interlude brings the same armchair operation to the world of hi-fi audio: volume, balance, tone, even input select — all controlled from the 'ideal listening position'.

Although this unit is intended as a plug-in module for the Prelude, it is almost a complete preamplifier in its own right. You only need a little ingenuity, a few hard-wired potentiometers and a power supply!

interlude

a remote-control
preamplifier

To provide a preamplifier with a remote-control facility, the first step is to ensure that all its controls can be operated by means of a DC voltage. The input selector switch, for example, could be replaced by a box of relays or by so-called analogue switches. However, relays are expensive and require heavy-duty drive circuits; conventional analogue-switch ICs are not bad, but they are not really good enough for a top-notch audio system.

The analogue controls (volume, balance and tone) are even more difficult. An ideal solution would be to use some kind of motor-drive for the potentiometers: just think of the gimmick-value of a knob that is rotated by a ghostly hand! Yes, and just think of the (mechanical) problems. Another alternative would be to use OTAs (Operational Transconductance Amplifiers) as electronic potentiometers. Unfortunately, their performance tends to be below par. To cut a long story short: any type of remote-control system in an audio installation

will have some disadvantage. Either it will be mechanically clumsy, or it will be expensive, or both; and if it is not too expensive, the quality will almost certainly be less than that offered by a more conventional preamplifier design. The solution chosen for the Prelude gets the best of both worlds, in a surprising way: use two preamplifiers! The Prelude itself is a top-quality design, using conventional controls. When switched from 'manual' to 'remote', its control section is cut out of circuit and replaced by a remote-controllable preamp: the Interlude.

This circuit configuration made the name 'Interlude' an obvious choice. Similarly, the infra-red transmitter and receiver (to be described in forthcoming issues) are called the 'Maestro' and 'Conductor', for an obvious reason: how else would you call someone who controls a musical performance from a distance? Not 'recording engineer', 'tonmeister' or 'producer', surely!

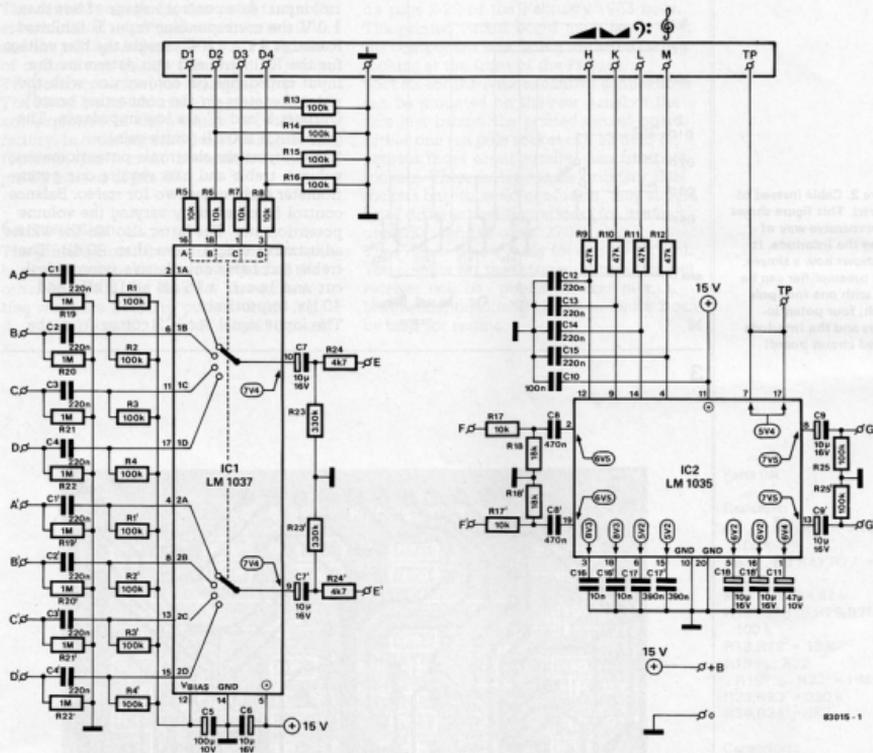

Second best?

As mentioned above, activating the Interlude means that the quality must suffer. This is the price of convenience. However, the overall specifications are not at all bad, as shown in table 1. The Interlude may not be XLent, but it certainly is hi-fi. For just two ICs, as shown in figure 1, that's not bad. These two, the National Semiconductor LM1037 and LM1035, are in a friendly environment of course: the input selector, IC1, only needs to select inputs of adequate level (approximately 100 mVRMS). These are provided by the tuner, tape deck or whatever, or by the existing phono preamps in the Prelude. The control amplifier, IC2, needs a fairly high signal level (1 VRMS or so) and this is provided by the existing line amplifier.

The circuit

IC1 is the equivalent of a double pole switch with four positions. Depending on the logic

Table 1

Typical technical data

Distortion factor (at 1 kHz, 1 VRMS output):	< 0,15%
Frequency range (+0, -1 dB):	20 Hz ... 20 kHz
Signal-to-noise ratio	
tuner, aux, tape:	> 75 dB
MM1, MM2:	> 65 dB
MC:	> 55 dB
Tone controls: bass (40 Hz):	± 15 dB
treble (16 kHz):	± 15 dB
Cross-talk (20 Hz ... 20 kHz):	> 40 dB
Volume control, range:	80 dB
Balance control,	
attenuation of 1 channel:	+1 dB ... -26 dB

Figure 1. The circuit of the Interlude merely consists of two ICs.

Figure 2. Cable instead of infrared. This figure shows an inexpensive way of testing the Interlude. It also shows how a simple, small preamplifier can be built with one four pole switch, four potentiometers and the Interlude printed circuit board!

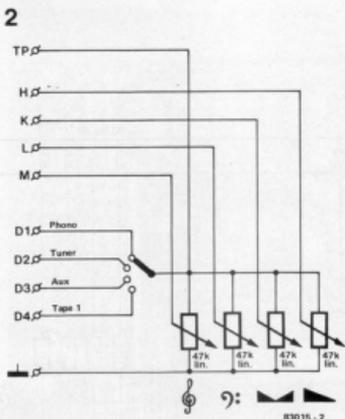

levels at control inputs D1 . . . D4, the corresponding signal inputs A . . . D (A' . . . D') are switched to output E (E'). In order to select an input, a voltage of 2.5 V . . . 50 V must be applied to the corresponding control input. At a control voltage of less than 1.0 V the corresponding input is inhibited. Resistors R1 . . . R4' provide the bias voltage for the IC inputs and also determine the input impedance (in conjunction with the potentiometers on the connecting board). Outputs E and E' are low-impedance. The gain of IC1 is 0 dB (unity gain).

IC2 contains six electronic potentiometers; volume, treble and bass require one potentiometer each, times two for stereo. Balance control is achieved by varying the volume potentiometer. The latter also has the widest adjustment range: more than 80 dB. The treble and bass controls give symmetrical cut and boost: ± 15 dB at 16 kHz and 40 Hz, respectively.

The input signal for IC2 comes from the

3

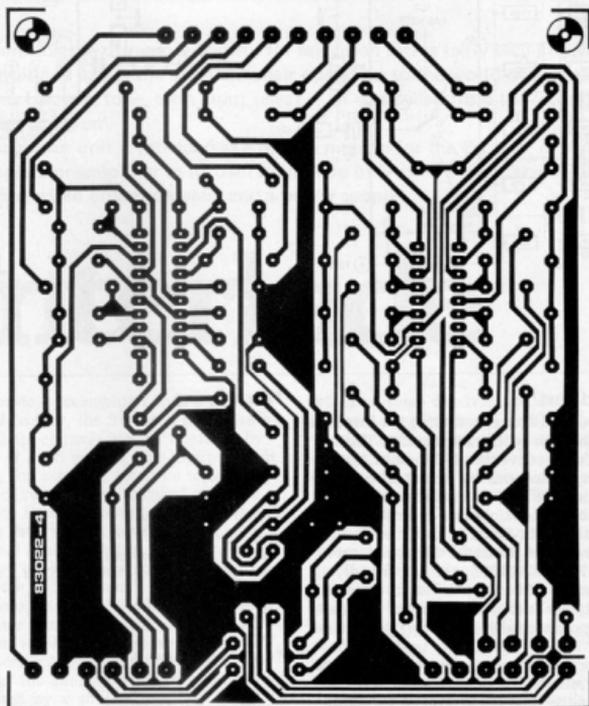

Figure 3. Terminals +B (15 V), A . . . D', E and E', F and F', G and G' and \perp are wired so that the printed circuit board can be 'plugged' into the bus board of the Prelude.

line amplifier of the Prelude, which delivers approximately $2 V_{rms}$. This signal (at points F and F') is reduced to the optimum input level of $1 V_{rms}$ for the IC by means of R17/R18 and R17'/R18'.

The control voltage for the potentiometers at terminals H...M can vary between 0 V and the voltage at point TP (5.4 V). A load of up to 5 mA can be connected to point TP (potentiometers, for example).

The IC offers an additional feature which is not exploited in the Prelude: a loudness facility. In order to make use of this optional function, pin 7 must be connected to pin 12 instead of pin 17.

Construction

The printed circuit board is mounted on the bus board in much the same way as all the other boards in the Prelude. The connecting wires are fitted to points +B (15 V), A...D', E and E', F and F', G and G' and

I. As usual, the short lengths of wire (about 2 cms) are soldered in place and then bent parallel to the board. This very economical 'edge connector' is fitted and soldered to the bus board in the position shown in figure 3 on page 2-20 of the February 1983 issue.

The printed circuit board must be fit with the component side facing to the left when looking at the front of the Prelude.

Sockets for the remote control connections can be mounted on the rear panel of the case just behind the printed circuit board. Either one ten pole socket can be used or, perhaps more economically, two five pole sockets. These latter can be ordinary DIN sockets but, to avoid confusion, they should be of different configurations (for instance, one 180° and the other 270°).

The Prelude is now ready for remote control.

The circuits for the infrared transmitter and receiver will be published next month.

Meanwhile, the circuit shown in figure 2 can be used for testing.

interlude
elektor april 1983

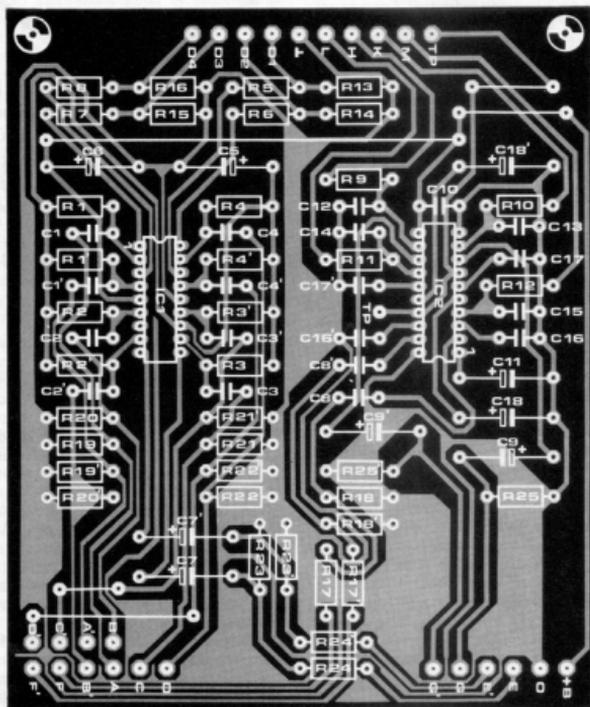

Parts list

Resistors:

R1...R4, R1'...R4' = 100 k
 R5...R8, R17, R17' = 10 k
 R9...R12 = 47 k
 R13...R16, R25, R25' = 100 k
 R18, R18' = 18 k
 R19...R22, R19'...R22' = 1 M
 R23, R23' = 330 k
 R24, R24' = 4k7

Capacitors:

C1...C4, C1'...C4', C12...C15 = 220 n
 C5 = 100 μ /10 V
 C6, C7, C7', C9, C9', C18, C18' = 10 μ /16 V
 C8, C8' = 470 n
 C10 = 100 n
 C11 = 47 μ /10 V
 C16, C16' = 10 n
 C17, C17' = 390 n

Semiconductors:

IC1 = LM 1037 (National Semiconductor)
 IC2 = LM 1035 (National Semiconductor)

frequency
response
equalisation
for moving
magnet
cartridges

RC equalizer

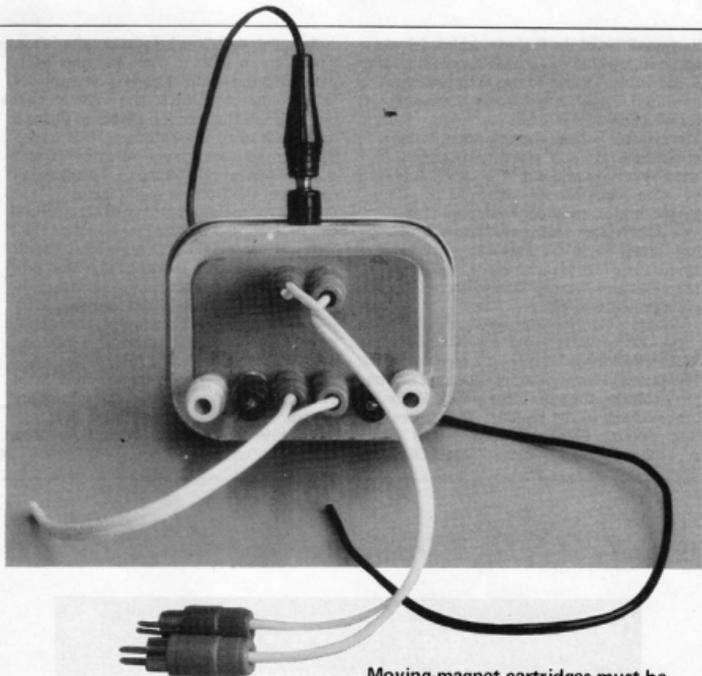

Moving-magnet cartridges must be terminated with the proper impedance in order to achieve optimum sound. This article attempts to clarify the electro-acoustic factors involved and presents a simple and inexpensive method of obtaining a great improvement in sound response.

Anyone who has purchased a record player or amplifier after extensive listening tests in a hi-fi studio will have noticed two things:

1. Each record player and each amplifier sounds different.
2. The new piece of equipment sounds different at home than in the shop.

One should not be tempted into resignation in the face of these idiosyncracies of audio-electronics. These differences in sound have a perfectly rational explanation and can be measured. The only question is how.

Figure 1. The electrical equivalent circuit of a moving magnet cartridge, connected to the pre-amplifier by a cable.

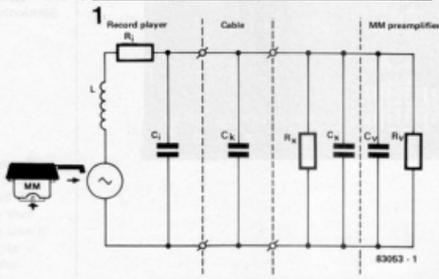

Cause and effect

The causes of the differences in sound can be found in the construction of a moving magnet system, and are explained by the equivalent circuit of this type of pick-up in figure 1. The stylus is connected to a small permanent magnet. Coils are arranged in its magnetic field and the field variations caused by stylus movement are converted to a varying voltage by these coils.

This type of coil has many turns. Since there is very little space in the cartridge, the wire used for the windings is very thin. In addition to the coil inductance (L : 200 mH ... 1 H), this leads to a considerable internal resistance (R_1 : 200 Ω ... 1000 Ω) and capacitance (C_1 : coil and cable, up to 100 pF).

Cartridges are designed to exhibit a flat frequency response when terminated with a particular impedance. In conjunction with the terminating impedance, the influence of L , R_1 and C_1 is neutralised. The DIN standard specifies a terminating impedance of 47 k/400 p.

Everything would therefore seem to be in order as long as $C_L + C_X + C_P$ result in 400 pF, and R_X and R_P in parallel have a value of 47 k Ω .

But things are seldom so clear-cut. Manufacturers of cartridges and hi-fi equipment tend to interpret this standard as 'merely a guide'. Cartridges are actually designed for terminating impedances of $33\text{ k}\Omega$... $100\text{ k}\Omega$ and for terminating capacitances of 80 pF ... 1 nF ; and readers who follow the tests in hi-fi magazines will have noticed that the input impedances of preamplifiers for magnetic pick-ups often deviate considerably from the values specified. Only so-called high-end equipment is provided with a means of selecting the input impedance. It is therefore no wonder that different performance is encountered when record players and amplifiers are combined in a system.

Phono-equalizer

Since we cannot change the cable capacitance C_L anymore than we can change the construction of the pick-up system, the only solution is to match the preamplifier.

Within certain limits, this is possible without modifying the unit, using a so-called phono-equalizer. This accessory is a box which is inserted in the line to the pick-up (or 'phono') input of the amplifier. Various capacitors and resistors can be switched in parallel with the input by means of push-buttons or other switches. In view of the very low cost of the components used in this accessory, it is clear that one is mainly paying for the technically sounding name 'phono-equalizer'. Furthermore, there is no guarantee that this accessory will result in any improvement.

According to the usual operating instructions, a record with plenty of overtones should be played and different settings should be selected on the phono-equalizer, until the sound is 'right'. In many cases, however, the result is merely a difference in sound and not a technical improvement. At any rate, it is not a solution worthy of the name 'hi-fi'.

RC equalizer

A better solution is to use an RC equalizer. As shown in figure 2, this accessory for home-construction simply consists of a metal box with two input sockets, two output sockets and four extra sockets.

The input and output sockets are interconnected; the box is therefore inserted in the line from the record player to the amplifier like a phono-equalizer. The extra sockets are intended to accept Cinch plugs containing a small capacitor or resistor.

In this way we have the equivalent of a phono-equalizer, i.e. a facility to connect capacitors and resistors in parallel with the input of the amplifier, but at much lower cost and with more flexibility.

The sockets must be insulated from the metal case; this is important to avoid hum. The easiest way to achieve this is to use plastic washers of a suitable diameter. The metal case then has an earth from the turntable, which is usually separate on most record players, and another terminal for the earth conductor to the amplifier.

2

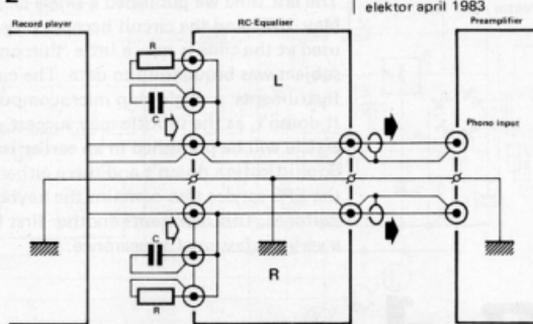

RC equalizer
elektor april 1983

83053 - 2

Incidentally, an RC equalizer of this type is already provided in the latest Elektor pre-amplifier - the Prelude.

Equalising

We now have a box with which we can connect capacitors and resistors as desired. So far so good. But what values do we need? We could consult the manufacturer's literature to establish what load impedance is required by the cartridge and what input impedance is provided by the preamplifier. Alternatively, we can use a test record. This should include a sine wave sweep from 50 Hz to 20 kHz or so.

Measurements can be done by ear, with the aid of the test circuit of figure 3 and a conventional, analogue multimeter. With the RC equalizer in circuit, we can now set to work.

1. Set the tone controls to their midpoints or, even better, switch them off if possible; cancel all filters (subsonic, loudness, etc.).
2. Play the record with the sweep, and adjust the volume record to obtain a readable deflection on the multimeter (test circuit connected to the loudspeaker output).
3. If the deflection remains constant at high frequencies ($\pm 15\%$ of the value for low frequencies is acceptable), the system is in order and no RC equalizer is needed.

If, however, the deflection clearly changes as the frequency rises, continue with the actual alignment: starting with small values for C (10 pF ...) and high values for R ($1\text{ M}\dots$), solder capacitors and resistors into the Cinch plugs. With the capacitor plugs and resistor plugs inserted in the auxiliary sockets, play the record with the sweep again and observe the deflection on the multimeter. This is repeated with different values of C and R until the flattest frequency response is obtained. It should be noted that C and R are mutually interactive.

If the frequency response can only be worsened with the RC equalizer, the input impedance of the preamplifier must be too low already. This means modifying the input circuit, but this is best not attempted without a circuit diagram.

Figure 2. The RC equalizer. Since it only consists of a box with six Cinch sockets and four additional plugs, it is considerably less expensive than a commercially available phono-equalizer.

3

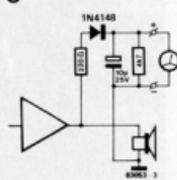
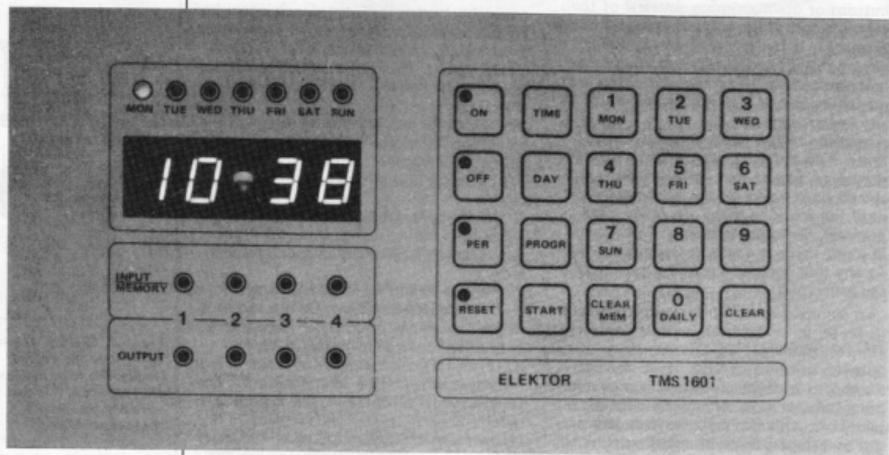

Figure 3. This test circuit allows even the highest frequencies to be measured with accuracy. It is connected in parallel with the loudspeakers.

The last time we published a single-chip programmable timer was way back in May 1979 and the circuit became very popular (and still is). However, the IC used at the time is now a little 'thin on the ground' and it's about time the subject was brought up to date. The circuit here uses the TMS 1601 from Texas Instruments, a single-chip microcomputer specifically designed for this purpose. It doesn't, as the subtitle may suggest, actually stop and start time itself (that article will be published in an earlier issue) but it will do almost anything else. Sophistication doesn't end there either. The front panel that is available from the EPS service also contains the keyboard, consisting of built-in membrane switches. This represents another first for Elektor and gives the finished project a very professional appearance.

7-day timer/controller



a micro
computer
controlled
time switch

The TMS 1601 timer/controller IC from Texas Instruments forms the basis of this circuit and, as can be expected, carries out most of the work. So what does it actually do? Briefly, it is a single-chip pre-programmed microprocessor dedicated to timer applications. It forms a 24 hour clock using seven-segment LED displays and provides four outputs that can be programmed for daily or weekly cycles (or both). It will also display the days of the week. With the aid of an external RAM (one of the few extra ICs) 28 different times can be programmed for each output per week. Alternatively,

four switching times for each output can be set to repeat daily. In total, this means enough switching times per week to take care of Coronation Street and Dallas and egg for breakfast every morning and still open and shut the garage door morning and night (weekdays only) without even struggling! Oh, and don't forget the porch light!

Contrary to what you might expect, programming this unit is a fairly simple matter. For example, say that the porch light needs to be switched on every Saturday evening for a certain period of time. Using the

keyboard, key in the day of the week followed by the switch-on time and then the switch-off time. That's all there is to it! Alternatively, if the porch light needs to be switched on every evening, as it probably will, simply press the 'DAILY' key.

All switching times that are stored in memory can be displayed whenever required. Each or all of them can be deleted or modified easily. There is also a 'reset' facility that may be of interest to people who have an application involving repeated 24 hour cycles, but more of that later.

One other mode of operation exists that can be very useful. It is possible to switch any output manually at any time without affecting the program stored in the memory. This has the added advantage that the timer can also be used as a central control point for all the appliances that are connected to it. Appliances can be connected to the timer via relays or solid state switches. These in turn can be mounted in the appliance itself or in the same housing as the timer. This allows the possibility of driving equipment using only low voltage wiring, a useful asset in a number of situations.

A final detail that is not the least in importance. The circuit has been equipped with emergency battery backup. This ensures that in the event of a mains failure the clock continues to run and the memory remains intact.

The circuit diagram

About a dozen or so years ago, the detailed description of the circuit diagram for this project would probably have required a small book! Fortunately this is not the case today as a glance at the circuit diagram of figure 1 will show. The heart of the circuit is IC7, the TMS 1601. This IC is a dedicated timer/controller microprocessor and we would not get anywhere without it (in this circuit at least). It contains an internal clock oscillator, 4 K byte ROM, 512 bit RAM and the four-digit seven-segment display decoder and multiplexer among other bits and pieces. Quite a tally for one IC!

The keyed information is stored in an external RAM, IC6. Three of the address lines for this memory are driven directly by IC7 while the others are controlled by a shift register, IC5. In its turn IC5 gets its information from output R9 of IC7, clocked in by a signal derived from output R11 (IC7).

The output control relays (or solid state switches if preferred) are switched via buffers (N8...N11) from the R12...R15 outputs of IC7. An important point to note here, the quiescent current of the output devices must not exceed 80 mA. The LEDs D19...D22 indicate the state of each output.

The membrane keyboard is connected between outputs R0...R9 and K1 and K2 of IC7. The key functions will be described later. The four seven-segment displays are multiplexed by IC7. The digit select outputs are R0...R3 and these

are buffered by display drivers N1...N4 in IC9. Segment control is from outputs 00...07 and here transistors T1 to T8 are the buffers. The remaining display outputs R4...R9 take care of the rest of the LED indicators (16 in all). It will be as well to list what these are. LD1 to LD4 are of course the seven-segment displays. These are accompanied by: a decimal point (D44), the days of the week (D32...D38), the memory input LEDs (D24...D27), an LED for the 'reset' (D28) and 'period' keys (D29) and finally the LEDs for the 'on' and 'off' keys (D31 and D30 respectively). The clock signal for IC7 is derived from the 50 Hz mains frequency and taken from the secondary winding of the transformer. The waveform at this point is used to synchronise the 7555 (IC4) which is connected as an astable multivibrator with a frequency of - 50 Hz! This apparent 'over-engineering' not only gives us a good square wave for the clock signal but it also serves as a clock oscillator if the mains supply fails. The frequency setting components in this case are resistor R2 and capacitor C5. This leads the story on to the power supply (emergency and otherwise). Two voltage levels are required for the circuit, -5 V and -9 V. Both are achieved by the use of voltage regulator ICs. The -9 V is the province of IC2; the -5 V supply consists of two sections, the supply for the display (IC1) and the rest of the circuit (IC3).

In the event of a mains failure (when panic sets in round the freezer!) the 7 NiCad cells take over - but not quite everything. The -9 V for IC4 and IC5 together with the -5 V for ICs 5 and 6 are maintained. This ensures that the clock continues to run and the memory remains intact. The display, with its relatively heavy current consumption, must go and so we lose that. The correct time is of course retained, it just means that it is no longer visible. Also we lose the drive to the relays, another heavy current consumer. This is not such a disadvantage however. How will the switched appliances operate during a mains failure? Unless of course someone invents a NiCad capable of opening a garage door by the time this gets into print! In the emergency situation the current requirement for the whole circuit does not exceed 50 mA and the NiCads can cope with this for quite a while. If the NiCads are to be replaced by non-rechargeable batteries R1 and D5 must be removed. These two components provide a 'trickle charge' for the NiCads.

Front panel controls

This section can be taken as a small commercial for our front panels which are self adhesive, scratch proof and washable. They also have that deep-down colour that will not fade if...but enough of that! On to the nitty-gritty!

The layout of the front panel is illustrated in figure 2. The control functions (an up-market term for keys and LEDs) can be described as follows:

Missing link?

For complete flexibility, it should be possible to program a mixture of 'weekly' and 'daily' times in one switching sequence. Unfortunately this is not possible - contrary to the manufacturer's specifications - as we discovered when testing our prototype. We have been informed that there is indeed an error in the programming mask for the chip. T1 is reluctant to correct this, which seems rather a pity -

Ed.

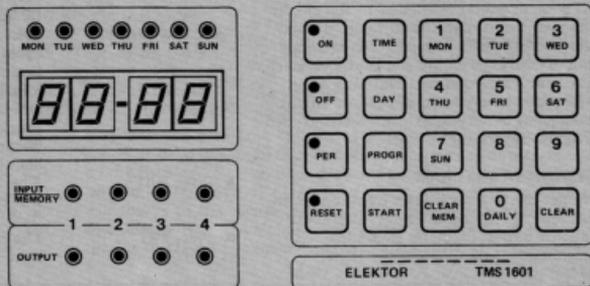

: It may come as a surprise but these LEDs indicate the days of the week!



The four digit time display. It is used to indicate the switching times during programming. (This is also true for the 'day' LEDs.) The centre LED flashes once a second.



: Four LEDs that indicate which of the four outputs is being programmed.



These LEDs indicate the state of the outputs.



: This key will switch on one of the outputs during the programming procedure or when under 'manual' control. The key lights when a switching 'on' time is entered.



: As above, but for 'on' read 'off'!



: This key is used before entering a time 'period' in place of a specific switch off time. The LED will light to denote that the next entry parameter will be a period.



: Similar to above but in this case it is a 'reset' time that will be entered and the LED will prove the point.



: The key used to start the clock or to switch the display back to real time (after a programming entry for instance).



: Used to select a particular day during programming or when setting the clock.



: A switching output can be programmed by operating this key followed by 1, 2, 3 or 4.



: This key is only used to get the clock out of the condition called 'single reset'. It will not be used very often and the reasons for this will be explained later.



: Remember this key because it will wipe out the entire memory if operated in error. It will do exactly the same job if operated on purpose but without anything like the same sort of 'after effects'!



: Deletes an incorrect key entry and clears the display.

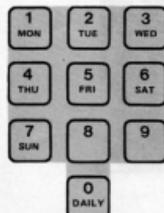

: These are dual function keys depending on the entry order of the specific program.

Figure 2. Ultra-thin membrane switches make it possible for the keyboard and front panel to be combined into one. The transparent covers for the display and LEDs are also part of the front panel.

Operation

From the word go . . .

As soon as power is applied to the circuit the four displays will flash figure 8's and the 'second' LED stay out. The memory will of course be empty and the clock will not run. This condition will also occur whenever the mains supply is lost and no emergency battery backup has been included. Need we say more?

Starting of the clock

We get off to a good start by using, as an example, 17.30 on a Friday afternoon! Did you expect 08.00 on a Monday morning?

- Press the TIME key : The MON LED will light and the display will show 00.00. This is quite correct because the cycle of the clock begins at 00.00 on Monday and ends at 24.00 on Sunday. The 'seconds' LED will light but not flash.
- Press DAY : The DAY LEDs will now start to flash.
- Press FRI : The FRI LED will light continuously

3

Parts List

Resistors:

- R1 = 270 Ω
- R2 = 39 k
- R3 = 1 k
- R4 = 120 k
- R5, R6 = 1k5
- R7, R8, R9 = 10 k
- R10 = 2k2
- R11 = 4k7
- R12 = 33 k
- R13 . . . R20 = 33 Ω
- R21 . . . R24 = 390 Ω
- P1 = 50 k preset

Capacitors:

- C1 = 2200 μ /25 V
- C2, C3, C4 = 22 μ /16 V
- C5, C8 = 10 n
- C6 = 10 μ /16 V
- C7 = 100 n
- C9 = 47 p
- C10 = 2 μ /16 V

Semiconductors:

- D1 = Red LED
- D2 . . . D5 = 1N4001
- D6 . . . D19, D39 . . . D43 = 1N4148
- D20 . . . D38 = Red LED, 3 mm ϕ
- D44 = Red LED
- T1 . . . T8 = BC547
- IC1, IC3 = 7905
- IC2 = 7908
- IC4 = 7555
- IC5 = 74LS164
- IC6 = HM 6147 (Hitachi) or 2147 (NEC)
- IC7 = TMS 1601 (Texas Instruments)
- IC8, IC9 = ULN2003

Miscellaneous:

- LD1 . . . LD4 = 7760
- B1 = Bridge rectifier B40C1500
- Tr1 = Mains transformer 12 V/1.5 A
- Cabinet CL2 AFJ from West Hyde
- Connector for keyboard contact strip available from Technomatic Limited

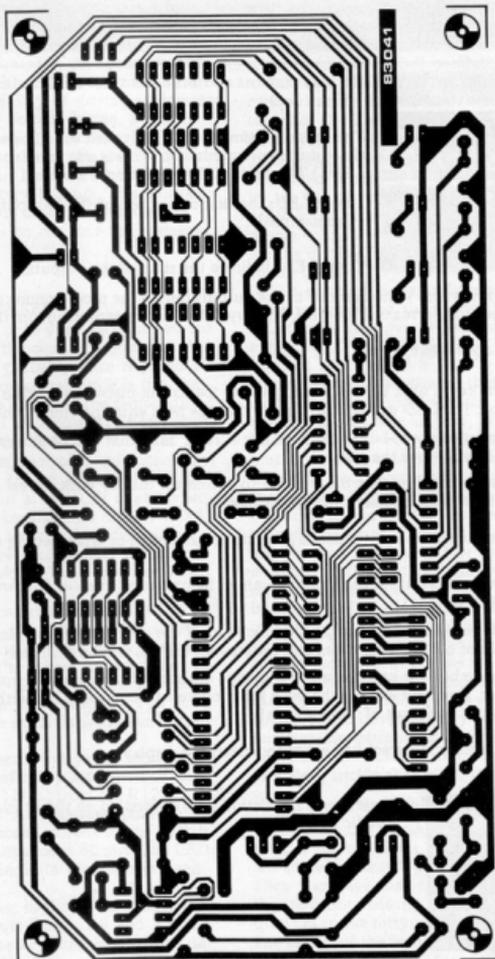

while the rest of the DAY LEDs will go out.

- Press the 1 7 3 0 keys in that order. This time will now appear on the display.
- Press the TIME key again and the displayed time will be entered into the memory.

The clock will now run – as indicated by the flashing 'second' LED. This will always be the case when 'real' time is displayed.

Time corrections

Changing the clock time (for British Summer Time for example) is almost identical to the initial starting procedure with the exception that the CLEAR key must be operated after the TIME key and before the DAY key.

Resetting

As stated previously, the clock cycle begins on Monday at 00.00 and ends on Sunday at 24.00. This can be altered if desired to another cycle period of less than seven days. If a reset time is entered the clock will, on reaching that time, 'jump' back to 00.00 Monday and repeat the shortened cycle again. Even this can be changed. If necessary,

7-day timer/controller
Elektron April 1983

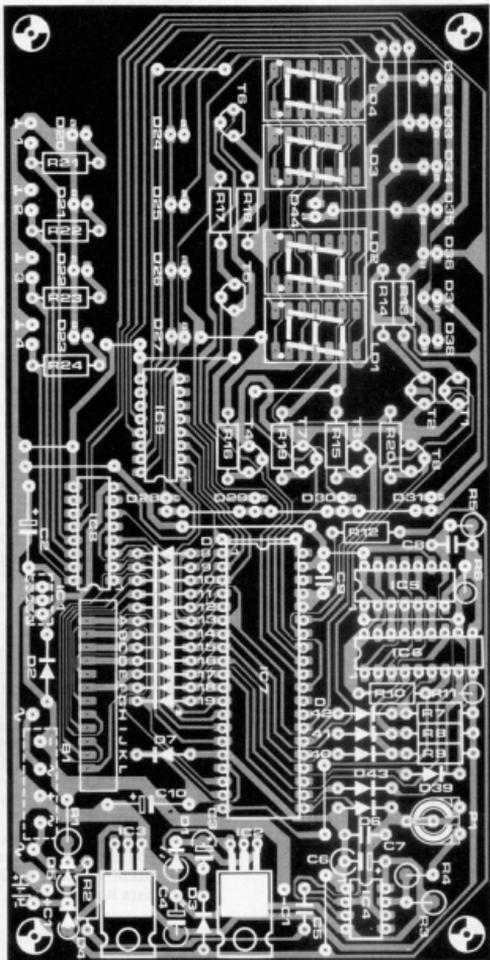

Figure 3. The keyboard is attached to the printed circuit board by means of a flexible flat connector strip. It is simply pushed into the edge connector on the printed circuit board.

the clock can be made to stay at 00.00 Monday when it returns there. This is called the 'single reset' mode and can be achieved by the removal of D19 from the circuit. When the clock enters into the single reset mode it can only be restarted by pressing the start key.

The reset time is entered in the following manner (again using 17.30 Friday as an example).

RESET DAY FRI 17.30 RESET.

The 'reset' LED will remain lit for the period of time that the reset time is stored in the memory. The reset time can be erased from the memory by operating the RESET followed by the CLEAR MEM keys. The stored reset time can be displayed at will by operating the RESET key twice in succession.

Manual control of the outputs

It is a simple matter to control the outputs manually if necessary. If, for example, it is required to switch on output 1, the sequence is:

PROGR 1 ON and there it is! This output will remain on until another (manual or program) instruction arrives to change it. Pressing the TIME key will cause the normal time to reappear on the display.

Programming switching times

One point must be made quite clear before moving on any further with this section. As mentioned earlier, there are two 'types' of programming times. There is the daily cycle where the timing point occurs every day, and there is the weekly cycle where the specific timing point may only occur once during the week (07.30 Friday for example).

As mentioned earlier, these modes cannot be mixed in one program sequence! A further point to bear in mind is that if, by chance, the same output is switched at the same time in either the weekly cycle or the daily cycle, that output will just be 'inverted' from what it was, irrespective of what the programs said it should do.

To program a switch-on time for output 1, key in:

PROGR 1 DAY FRI 1730 ON

Two things may happen after pressing the ON key.

1. It is possible that the display disappears for a short period while the program is being written into memory. This is not a problem and is no cause for alarm.
2. The number 1 output will be switched on if the time entered is earlier than the time indicated on the display.

Entering a 'daily' time is almost identical to the above program. In this case the DAILY key is operated instead of the 'day' (FRI) key. The sequence of events then, for output number 1 to switch off at 23.00 every evening, would be:

PROGR 1 DAY DAILY 2300 OFF

Note that all 'day' LEDs will light when programming a 'DAILY' function.

Programming hints

Point 2 mentioned above states that when programming switching times that are earlier

than the time displayed at that moment, the output (or outputs) will switch on or off depending on the program instruction being entered. This can be avoided to a certain degree by entering the last switching time (that is before the actual time) first. The corresponding output will then remain in that condition.

It is not necessary to enter switching times in any particular order as the computer deals with this problem personally!

Another tip! It is not necessary to operate the PROGR and DAY keys repeatedly when entering a sequence of switching times for one output. The following example will clarify this. It is required that output number 4 is to switch on at 7.00 and off at 12.30 on Wednesday.

PROGR 4 DAY WED 7 0 0 ON

followed by:
1 2 3 0 OFF

Period (PER) function

Using the PER key is an alternative method of indicating the switching off time. In the event that output number 3 is to be switched on at 9.00 on Monday and remain in this state for a period of 6 hours, the program would look like this:

PROGR 3 DAY MON 9 0 0 ON

and then:

6 0 0 PER

the display will now show the switch off time that has been calculated by the computer and stored in memory (15.00 in the example here).

Displaying and clearing switching times

Human memories, regrettably, do not measure up to the short term performance of 'solid state' memories. Therefore it is quite likely that a reminder may be required. In order to display the first programmed time for an output, this apparent nonsense is entered:

PROGR 1 PROGR PROGR

followed by:

PROGR PROGR

This will cause all the switching times that are stored in memory for that output to be displayed in chronological order. If nothing has been entered for that output the displays will show 8's and all other LEDs will light.

Clearing the stored switching times is very similar to the above procedure. Now the CLEAR MEM key must be used when the time in question appears on the display. This time is then cleared and the processor will display the next switching time when the PROGR key is pressed once.

If necessary, it is possible to clear the whole program for a given output in one go. For output 1 for example:

PROGR 1 CLEAR MEM

For really drastic measures, the whole memory contents can be wiped out.

CLEAR MEM CLEAR MEM

... and there it was - gone!

Errors

... and the last entry is keyed in to complete the program and ... the display starts flashing 8's, the 'seconds' LED gives up and panic is

about to break out! It's difficult to decide whether to make a dive for the mains plug or lift the box up to stop it from scorching the table top...!
Panic not, for what you are receiving is simply an 'error' indication. In this case an incorrect key was pressed (the last one of course) and this can be rectified by either pressing the correct one or using the CLEAR key and starting all over again. Don't you just know which method it will be!
It is also possible for the displays to show 8's but the 'seconds' continue to function. This is a memory error or 'overflow' (caused by trying to fill the same memory area twice). Afraid it's back to the CLEAR key!

Construction

We really should have a short commercial here extolling the undoubted virtues of printed circuit boards, front panels and membrane-switch keyboards designed specifically for the job but we will forego that for the moment. Instead we move on to figure 3 which illustrates the component layout for the printed circuit board. All the components shown in figure 1 can be mounted on this board with the exception of the transformer, the NiCad cells, the relays and the keyboard.

Figure 4. This drawing illustrates the construction. The printed circuit board, the front panel of the cabinet and the self adhesive front panel form one combined assembly.

4

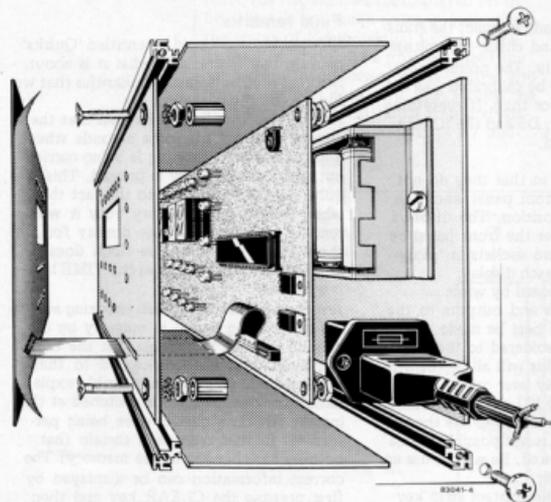

Two components demand particular attention and these are the electrolytic capacitor C1 and the bridge rectifier B1. These are mounted last, not on the front but on the trackside of the board. It will be necessary to place a layer of insulating tape between the body of the electrolytic and the board to prevent any untoward horrors from occurring.

Keyboards have a history of being rather difficult to mount properly. There is all that soldering and that great gaping hole to cut which never seems to quite line up correctly (although it did when you started!). This time we have solved the problem — as if you didn't know by now! Not one solitary screw is required because the membrane switch keyboard consists of a number of layers of plastic foil and consequently is very thin (a matter of a couple of millimetres). In fact, it is an integral part of the front panel. For a more detailed description of membrane switches refer to the separate article on the subject elsewhere in this issue.

The front panel, together with keyboard, is self adhesive and only needs to be placed on the front of the chosen cabinet and pressed home. The keyboard contacts 'come out' on a flexible flat plastic strip which is attached to the printed circuit board by pushing the strip into a connector that is mounted on the board.

Figure 4 provides an indication of how the prototype looks. Construction is straightforward and only requires the usual patience and attention to detail. We used a metal case so that the entire circuit can be effectively screened. This is done by connecting the case to the supply zero. It will be found preferable to use a case that enables the front panel to be removed as there are a number of holes that must be cut out. The CL2 AFJ case from West Hyde is ideal for the purpose as the front panel is both removable and exactly to the correct dimensions.

The following is a suggested sequence of events for construction:

1. Assemble the printed circuit board.
2. Cut the holes in the front panel for the display, the LEDs and the flexible connecting strip for the keyboard. Do not forget to drill and countersink the holes for the spacers that will carry the printed circuit board on the back of the front panel. This will be clear from the illustration in figure 4. Take care to ensure that the holes line-up with those in the printed circuit board. When the front panel is prepared, the spacers can be fitted using counter-sunk screws. Care taken at this stage will handsomely repay the effort. It is not a bad idea to cover the inside on the front panel with a layer of insulating material to guard against the possibility of short circuits.
3. With great care, fit the self-adhesive front panel in place and apply a little pressure over all its surface.
4. Now it is time to screw the printed circuit board in position.
5. Finally the transformer and the NiCad cells can be fitted in the interior of the

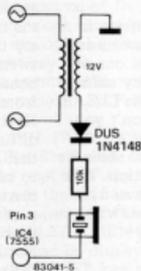

Figure 5. Fully monaural calibration is used to set the frequency of the emergency standby power supply. The only other requirement is one human ear!

cabinet. The relays or solid state switches can also be mounted now if it is intended that they are to live with the rest of the circuit.

If ordinary relays are to be used it is recommended that an RC network consisting of a 100 Ω /1 W resistor in series with a 100 nF/630 V is wired across their contacts to avoid interference caused by 'sparks'. The rear of the cabinet will also require a few holes made for the mains supply lead and the switching outputs. Do not insert ICs 4...8 into their sockets until the construction of the printed circuit board is complete. The same goes for the emergency supply and R1 and D5. The voltage level on the -9 V supply will be incorrect when R1 and D5 are fitted and IC4 and IC7 are not.

When the board is ready connect the transformer, switch on, and check the voltage levels from the supply. The preset potentiometer P1 can now be calibrated (see the calibration chapter for this). If everything is as it should be, R1, D5 and the ICs can be fitted to the board.

Some finer points:

- Mount the LEDs so that they do not quite touch the front panel when the board is fitted in position. The displays can be brought nearer the front panel by mounting them in two sockets in 'piggy-back' fashion under each display. Connections to the board by wires carrying the supplies and outputs to the relays and so on can best be made using printed circuit pins soldered to the track side of the board. This will allow them to be reached quite easily later on. The voltage regulator IC1 must be mounted in some convenient position to use the case as a heat sink. If this is not possible then a heatsink will be required. Be sure to use an insulating mica washer.
- The position of the contact strip key-board at the back of the front panel is shown in dotted lines in figure 2. This drawing can be used as a pattern when cutting the holes in the cabinet front panel. Remember to make an opening for the contact strip.
- It may be found easier to cut the front panel to the exact size before fitting it

in place on the cabinet front panel. Obviously a sharp knife will be needed for this purpose. Do not cut off more than 10 mm from the top or bottom edges and not more than 20 mm from the sides.

Calibration

The astable multivibrator (IC4) will always be synchronised to the mains frequency during normal operation. If an emergency standby supply is not to be used then calibration of P1 will not be necessary. Setting P1 to its mid position will be fine. If, on the other hand, an emergency backup is fitted then IC4 must be calibrated to provide an output frequency of 50 Hz, even in the absence of a mains supply. Obviously this calibration will be a simple matter with the aid of a frequency counter. However, a reasonably accurate setting can be achieved without it. All that is required in the way of test equipment is an ordinary crystal earpiece or piezo tweeter.

It happens like this:

- For safety's sake remove all the ICs from the printed circuit board with the exception of IC4 and the voltage regulators.
- Disconnect the power from the mains.
- Connect the earpiece or tweeter as shown in figure 5.
- Connect the batteries or NiCads for the emergency supply.
- Rotate P1 until the tone from the earpiece is as pure as it is possible to get, without any obvious 'beat'.

That completes the calibration procedure! The batteries must again be disconnected before mounting the ICs on the board.

Final remarks

This last chapter could be entitled 'Quirks' because that is precisely what it is about. Not real problems, just peculiarities that we found with the prototype.

Here is the first. It may happen that the display goes off for some seconds when a lot of program entering is being carried out and the TIME key is pressed. This is quite normal and is due to the fact that when the processor is very busy it will tend to 'forget' about the display for a short period of time. The clock does in fact begin to run as soon as the TIME key is operated.

A second peculiarity. When checking switching times being stored in memory by displaying them, it is possible that the time displayed does not correspond to that being stored. There is one feasible explanation for this. The clock switched at the instant the time checks were being performed. In that case, it is certain that nothing has changed in the memory! The correct information can be displayed by first pressing the CLEAR key and then continue with the required procedure for checking stored switching times. Last but not least. The display will flash for one full minute at 00.00 (except for Sunday at midnight). This was considered rather strange but it seems to be normal for the TMS 1601 so don't pay any attention to it!

P. Wild

a valuable aid
in writing
programs

You have written your own program. Now it is merely necessary to enter the program and run it. In many cases however, the bugs are having a field day. Where does one start with debugging? The first items to check are the contents of the accumulator, the X- and Y-register and the processor status register. This is usually the quickest way of finding possible errors.

junior program tester

The register check is not very complicated and is a great aid to all Junior Computer owners. In order to display the contents of the accumulator and of the X- and Y-register only a few commands are needed; these are contained in the program and ensure that the contents of the accumulator and of the X- and Y-register are displayed from left to right. A few commands are also contained in the program for displaying the processor status register. Something more is required, however. In addition to the software a small hardware change is needed; figure 1 shows the circuit. Since there is insufficient space on the display for hexadecimal representation of the processor status register contents, the flag statuses are displayed bit-by-bit (there is not much point in indicating the status of the individual flags in hexadecimal notation). The program loads the contents of the processor status register into port A. An 8-bit data latch, IC1, accepts the logic states of the individual flags and displays them using drivers N1 ... N7 and LEDs D1 ... D7.

The circuit of figure 1 should be constructed on an additional board which can then be plugged into the port connector when needed. The program to be tested is provided with a BRK command at a suitable point, and the BRK vector must point to the start of the following test program:

85	FB	STA POINTH	
86	FA	STX POINTL	
84	F9	STY INH	
68		PLA	Fetch processor status register and load it into port A
8D	80	1A	STA PAD
A9	FF		LDA # FF
8D	81	1A	STA PADD
8D	83	1A	STA PBDD
			Port A output = status register and Port B output = clock signal for FF1 ... FF7
/ 20	8E	1D	JSR SCANDS
4C	XX	XX	JMP
			Back to /

The only escape from the test program is via RST.

1

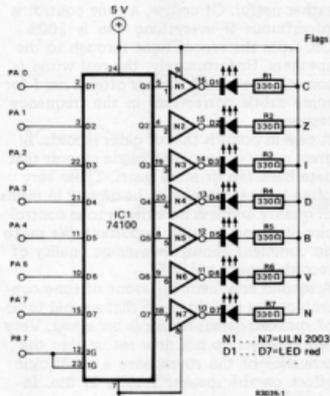
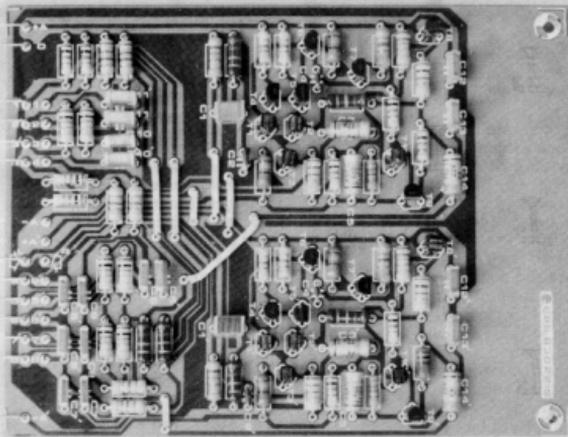

Figure 1. Two IC's, seven resistors and seven LEDs: the total hardware investment.

The end is in sight! We have now reached the final constructional article in the Prelude series: the printed circuit board for the tone control. This circuit is not entirely essential for a control amplifier but it can be useful. This is especially true if it has switchable turnover points for the filters. And (the height of sophistication!): a tone defeat switch, enabling the filter circuit to be taken out so that the tone controls have no effect on the signal.

(Part 3)

Prelude



tone control

The first question that demands an answer is: Why do we have a tone control for the Prelude? After all, it was stated at the outset that we would do our utmost to keep the 'processed' signal as pure as possible and now we are suddenly discussing tone controls. What have they to do with high quality reproduction? Not a lot! However, situations can arise where a tone control may prove rather useful. Of course, a tone control is superfluous if everything else is 100% OK from the record right through to the speakers. Unfortunately, the real world is something else and there is often a need for some subtle corrections in the frequency response.

A case in point is that of older records. A great many collections include records that date back ten or more years. These very often leave something to be desired in terms of quality and it is here that a tone control circuit becomes fairly important. We make no comment about the average quality of records bought today!

A second argument in favour of tone controls comes to light when that age-old topic of speakers-versus-rooms is broached. Very few listeners do not now realise that the acoustics of the room have a significant effect on the speaker system in use. Inadequacies can be compensated for by the educated use of the tone circuit. To a certain degree, a 'cost-effective' speaker can

also be given a helping hand.

It is also true to say that not every listener's hearing is the same, especially if years are beginning to tell. We now have a situation where a tone control is very necessary. And let's not forget Mr Average, a member of the vast majority who likes to hear what he likes to hear - especially the bass! And what is wrong with that, may we ask?

When all is said and done then, we feel that most people would welcome the tone control circuit here. The added facility of the two switched turnover points for both the high and the low frequencies make it quite useful. The 'straight-wire' fanatics have the tone defeat switch to satisfy them. When operated this, as its name suggests, takes all the tone control elements out of circuit.

The tone control in detail

The complete circuit diagram of the tone control is shown in figure 1. This again follows the concept of the line and headphone amplifiers (T1...T9). The detailed description of the amplifier circuit itself will therefore be found in the articles covering the line and headphone amplifiers (February and March 1983). A lightning trip through the circuit goes like this:

The input is fed to T1 which, together with T2, makes up a differential amplifier with a current mirror (T4 and T5) in its collector lines. The signal is then fed to the output stage consisting of T8 and T9 via the darlington pair, T6 and T7. This configuration provides considerable gain. The dc current setting of the differential amplifier is taken care of by T3, while T10 looks after the darlington (and therefore the output stage). These two transistors are connected as current sources. The input signal is fed to the base of T1 while the feedback arrives at the base of T2. Part of the tone control network is included in the feedback loop.

It is now time to take a little side-step into the tone control circuit because it is slightly different from that usually expected. The most frequently used tone control circuit is the Baxandall. This is an active circuit that makes use of the feedback loop of the amplifiers. Its principle of operation is illustrated in figure 2a. A frequency dependent potentiometer P forms the feedback loop of the amplifier: the input signal is present at one side of the potentiometer and the output signal at the other. If we take the impedance of the left part of the potentiometer as Z1 and the impedance of the right side as Z2, then the gain will be $\frac{Z2}{Z1}$. This means that

the input and output signals will have the same value when the wiper of the potentiometer is in the mid position. It follows then that rotating P clockwise will increase the impedance of Z1 by the same amount

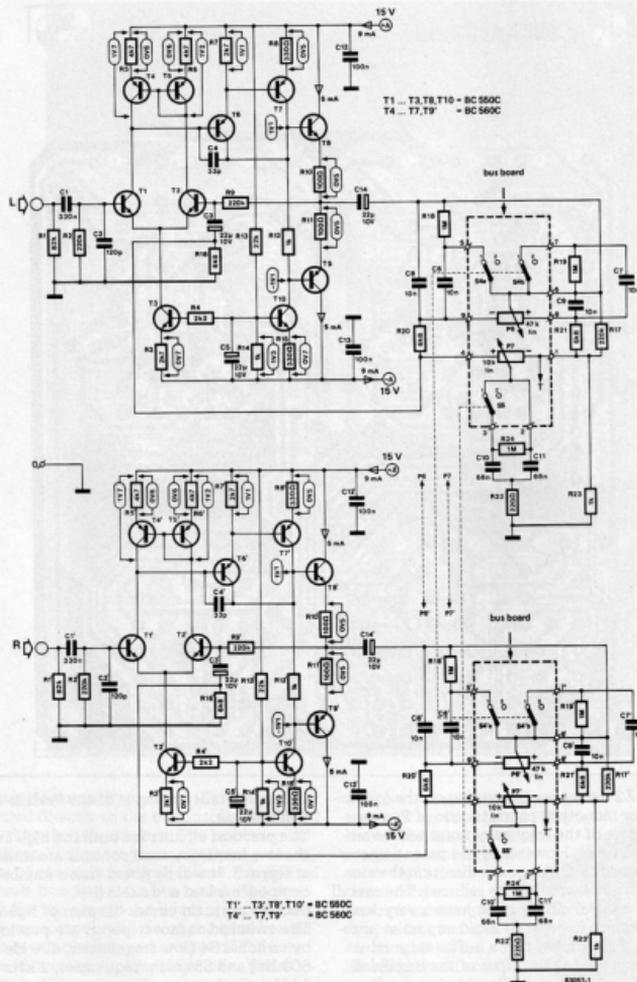
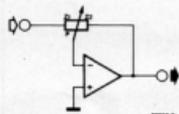

Figure 1. The circuit diagram of the tone control for the Prelude. The basis of the circuit is a high quality discrete opamp that has been used in other sections of the Prelude preamplifier.

2a



2b

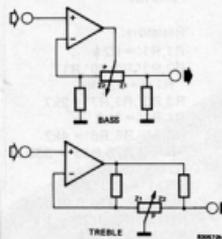

Figure 2. The usual configuration of a Baxandall tone control network is illustrated in figure 2a. The circuit in the Prelude is a modified form of this (figure 2b). The major difference is that the first requires a buffer stage and the second doesn't.

3

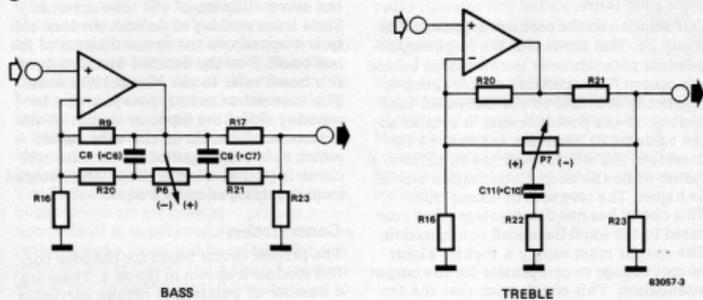
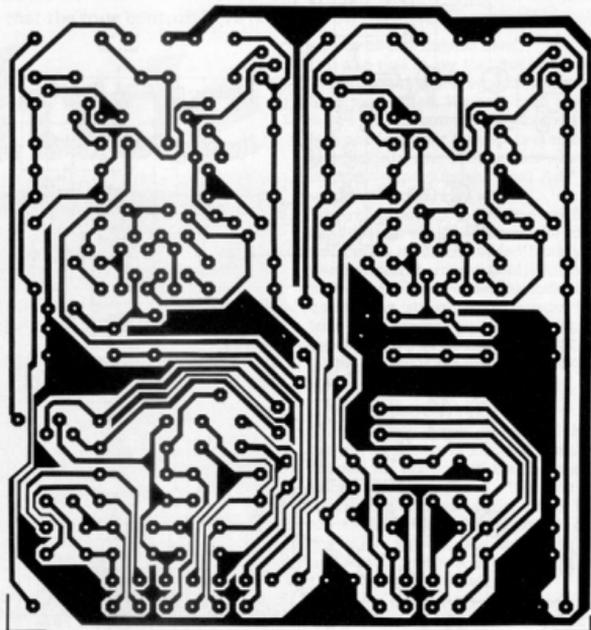

Figure 3. This figure shows those components that are included in the high and low frequency control circuits. The component numbers in brackets refer to the capacitors that are switched.



Parts list

Resistors:

- R1, R1' = 82 k
- R2, R2', R9, R9', R17, R17' = 220 k
- R3, R3', R7, R7' = 2k7
- R4, R4' = 2k2
- R5, R5', R6, R6' = 4k7
- R8, R8', R15, R15' = 330 Ω
- R10, R10', R11, R11' = 100 Ω
- R12, R12', R14, R14', R16, R16', R23, R23' = 1 k
- R13, R13' = 22 k
- R18, R18', R19, R19', R24, R24' = 1 M
- R20, R20', R21, R21' = 6k8
- R22, R22' = 220 Ω
- P6, P6' = 50 k (47 k) lin. stereo potentiometer*
- P7, P7' = 10 k lin. stereo potentiometer*

Capacitors:

- C1, C1' = 330 n
- C2, C2' = 120 p
- C3, C3', C5, C5', C14, C14' = 22 μ /10 V
- C4, C4' = 33 p
- C6 ... C9, C6' ... C9' = 10 n
- C10, C10', C11, C11' = 68 n
- C12, C12', C13, C13' = 100 n

Semiconductors:

- T1, T1', T2, T2', T3, T3', T8, T8', T10, T10' = BC 550C
- T4 ... T7, T4' ... T7', T9, T9' = BC 560C

Miscellaneous:

- S4 = 4-pole, 2-way*
- S5 = 2-pole, 2-way*

* mounted on bus board

that Z2 decreases. Depending on the (capacitive or inductive) characteristic of P, a certain part of the frequency range will be amplified more. However, if the potentiometer is rotated in the opposite direction the amplification factor will be reduced. The overall tone control circuit must have a very low impedance in order to avoid any noise problems. This implies that a buffer stage must be employed at the input of the Baxandall tone control circuit. Considering the fact that a high quality buffer stage would require a lot of components, we opted for another circuit that needs only a single amplification stage.

Our solution to the problem is presented in figure 2b. This shows that the frequency dependent potentiometer is now placed behind the opamp. The operation of this circuit is practically identical to the Baxandall tone control. If the potentiometer is rotated so the value of Z1 increases and that of Z2 decreases, this would lower the amplification factor while the output attenuation would be higher. The reverse is of course true.

This circuit has one disadvantage when compared to the usual Baxandall configuration. The output must supply a slightly higher output voltage to compensate for the output attenuation. This could mean that the amplifier will start clipping at higher input signal levels but this problem will not occur

if the presets at the input of the Prelude are correctly set.

The practical circuits for both the high and the low frequency tone controls are shown in figure 3. It will be noted that a number of components lead a 'double life'.

Back to the main circuit diagram of figure 1. The switched turnover points are provided by switches S4 (low frequencies, 400 Hz and 800 Hz) and S5 (high frequencies, 2 kHz and 4 kHz). Each switch changes the value of the frequency determining capacitors by adding a further capacitor in parallel.

The tone defeat switch, S12, is not shown in the circuit diagram of the tone controls.

Since it has nothing to do with the tone controls it appears on the circuit diagram of the bus board. For the detailed description of this board refer to the March 1983 issue.

The tone defeat switch does just that by selecting either the input or output of the tone control circuit. If the tone defeat switch is 'in', the input of the tone control circuit is grounded and is therefore prevented from supplying an output signal.

Construction

The printed circuit board for the tone control module is shown in figure 4. There are a number of points that require particular attention during construction.

The switches S4 and S5 and the stereo

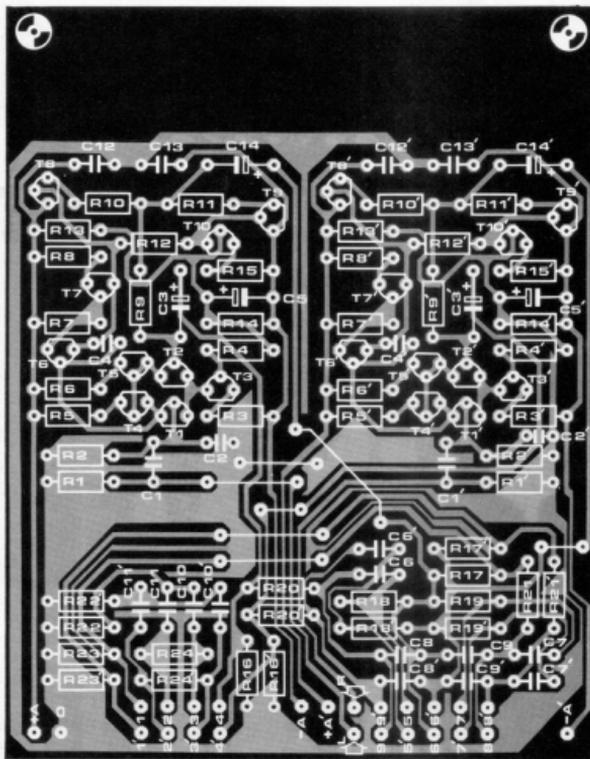
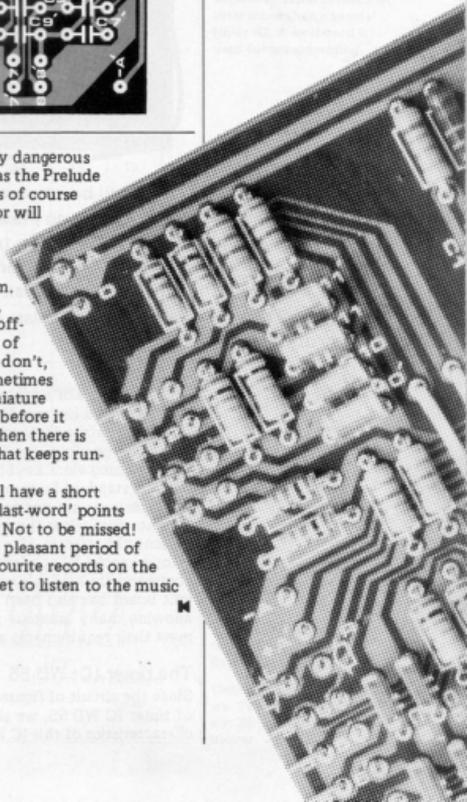

Figure 4. The printed circuit board of the tone control stage. There are two rows of connecting points that must be connected to the bus board by short wire links.

potentiometers P6/P6' and P7/P7' are connected directly to the bus board with the aid of short lengths of wire. The next step requires a little more patience. There are two sets of connecting links between this printed circuit board and the bus board. The row nearest the edge of the board are connected on the component side of the board while the row farthest from the edge of the board are connected on the track side. Short lengths of wire (resistor offcuts!) are soldered in place so that they stick-out from their allocated side of the board. Those on the component side can be bent to run parallel with the board. The same will happen to those on the track side but they must first be covered with a short length of sleeving to prevent any nasties happening. Take note that the component side of the tone control board faces towards the right when looking at the front of the Prelude. A little patience is needed when fitting the 'edge connector' into the mother board to ensure that problems do not arise.

The Prelude is now complete and testing can begin. If visitors are present – prepare to act nonchalant! A signal source will of course be required and a tuner will be suitable for this purpose. An amplifier and a pair of speakers would also be convenient! After checking to see that all switches and controls are as they should be – just switch on!

This is an extremely dangerous moment! As soon as the Prelude bursts into life – as of course it will – your visitor will suddenly realise that an electronics genius is standing right in front of him. Without hesitation, he will proceed to off-load an assortment of tape recorders that don't, televisions that sometimes do and a micro-miniature radio that was fine before it 'fell' in the bath! Then there is this battery razor that keeps running down and . . . Next month we will have a short article concerning 'last-word' points of note and things! Not to be missed! Meanwhile, enjoy a pleasant period of trying out your favourite records on the Prelude. Don't forget to listen to the music sometimes . . .



programmable darkroom timer

convenient IC
allows simple
construction

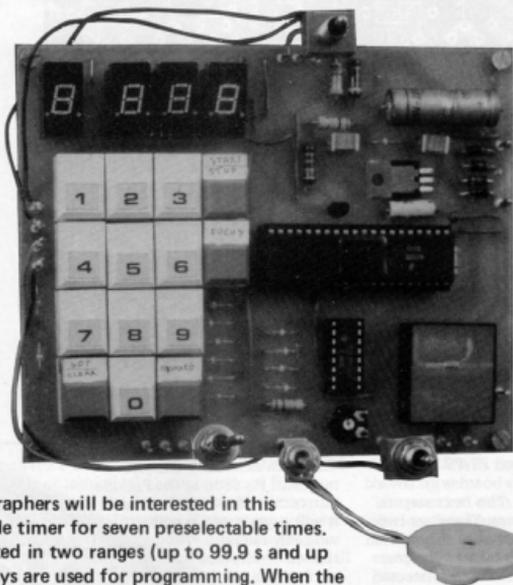

Many amateur photographers will be interested in this circuit: a programmable timer for seven preselectable times. The time can be adjusted in two ranges (up to 99.9 s and up to 999 s). Fourteen keys are used for programming. When the start key is pressed, the time countdown can be observed on the display. The preset value then reappears on the display. There is therefore no need for repeated entering of the proper exposure time.

The advantages of a programmable darkroom timer are well known. Most manufacturers now try to make their equipment as simple to use as possible. An LED display and programming via a keyboard have almost become standard features. Clearly, however, these features are not inexpensive. Elektor has therefore taken the opportunity here to present this circuit of a darkroom timer using a special IC as a low-cost alternative to commercially available units. A printed circuit board has also been developed, thus allowing many amateur photographers to meet their requirements at last.

The timer IC: WD 55

Since the circuit of figure 1 chiefly consists of timer IC WD 55, we shall examine the characteristics of this IC in some detail. The

manufacturers describe their product as a versatile timer module which can replace all mechanical timers in control engineering. Without wishing to dispense free publicity, we can nevertheless say that this IC is ideally suited to our application.

The device is a 4-bit microprocessor with on-chip (preprogrammed) ROM. In other words, all the characteristics described in the following are already provided, except for a few which are selected externally. The processor can operate in two modes: as a key-programmable timer/controller, the internal RAM is used as a data memory and a 4-digit, 7-segment display provides the readout. In its other mode, the processor operates as an on/off timer: switches or diodes serve as data memory and data readout; there is therefore no need for a display.

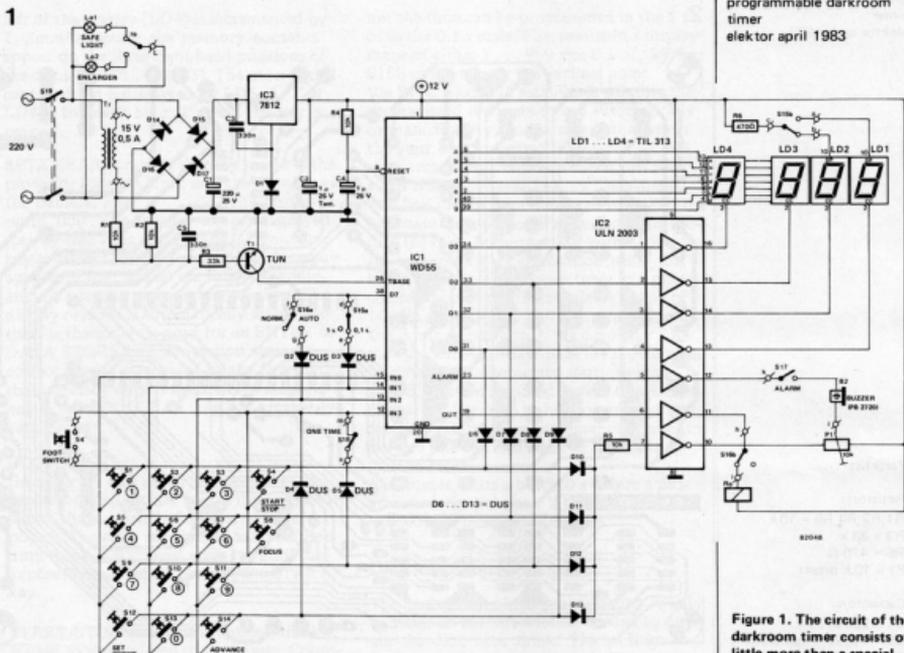

Figure 1. The circuit of the darkroom timer consists of little more than a special timer IC. A keyboard is used for programming.

Incidentally, the principle of such a timer was presented in the 'wide range darkroom timer' in the October 1981 issue. The two modes are selected by means of a diode between pin 38 and pin 15 of the IC. If the diode is omitted, as is the case in this application, the processor operates as a key-programmable timer/sequence switch. In this mode a keyboard and a 4-digit, 7-segment display are required. The processor can then be utilised as an ideal darkroom timer. Figure 1 shows the complete circuit.

Programming

The timer is programmed via a keyboard arranged in a 4 x 4 matrix. Table 1 shows the functions assigned to the individual keys. The cross-hatched boxes show that certain functions are or can be permanently selected with these connections. Fourteen keys are needed to make the timer freely programmable. Each keystroke is acknowledged by a beep from the piezo-electric buzzer. Thus it is also possible to use a sensor-type, touch-keyboard. However, one imperfection is associated with this key-actuated operation: the operation is only initiated when the key is released (except for the stop-function). But one quickly becomes accustomed to this. The key functions in detail: **ADVANCE:** this key is used to step through the memory (RAM) stages. There are seven stages altogether, allowing several different times to be programmed. With each key-stroke, the memory number on the extreme

Table 1

pin	15	14	13	12
31	1	2	3	START/STOP
32	4	5	6	FOCUS
33	7	8	9	ONE TIME
34	SET/CLEAR	0	ADVANCE	30 Hz
38		0.1 V 1 s	NORM/AUTO	



Table 1. Functions of the timer IC when used as a darkroom timer.

Outputs:
 pin 19 - relay
 pin 25 - piezo-electric buzzer

Parts list

Resistors:

R1, R2, R4, R5 = 10 k
R3 = 33 k
R6 = 470 Ω
P1 = 10 k preset

Capacitors:

C1 = 220 μ /25 V
C2 = 1 μ /25 V tantalum
C3, C5 = 330 n
C4 = 1 μ /25 V

Semiconductors:

D1... D13 = DUS
D14... D17 = 1N4001
LD1... LD4 = TIL 313
(common cathode)
T1 = TUN
IC1 = WD-55 Pronto Elec-
tronics (01-599-3041)
IC2 = ULN 2003
IC3 = 7812

Miscellaneous:

Tr = mains transformer
15 V/0.5 A sec.
S1... S14 = Digitast SR
S15, S16 = double-pole
changeover switch
S17, S18 = single-pole
switch
S19 = double-pole
mains switch
Bz = piezo-electric buzzer
(e.g. PB 2720)
Re = 12 V Siemens pcb
relay V23027-A0002
(electrovalve)

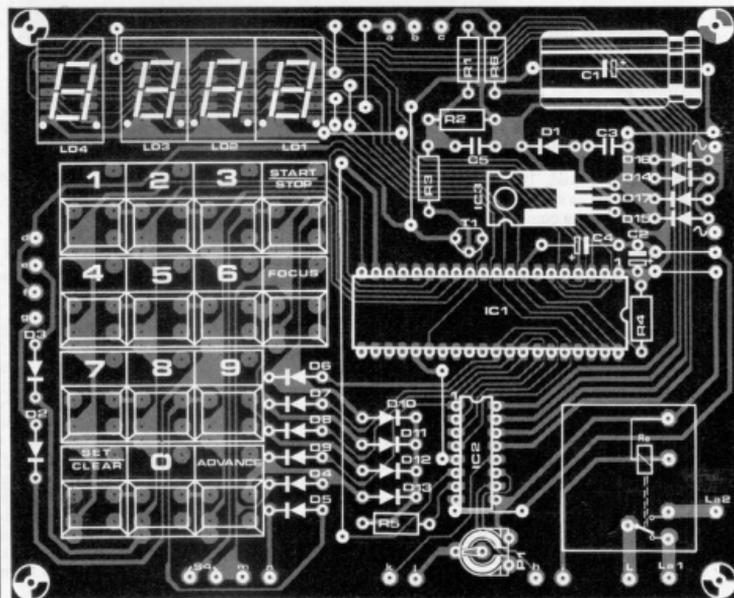
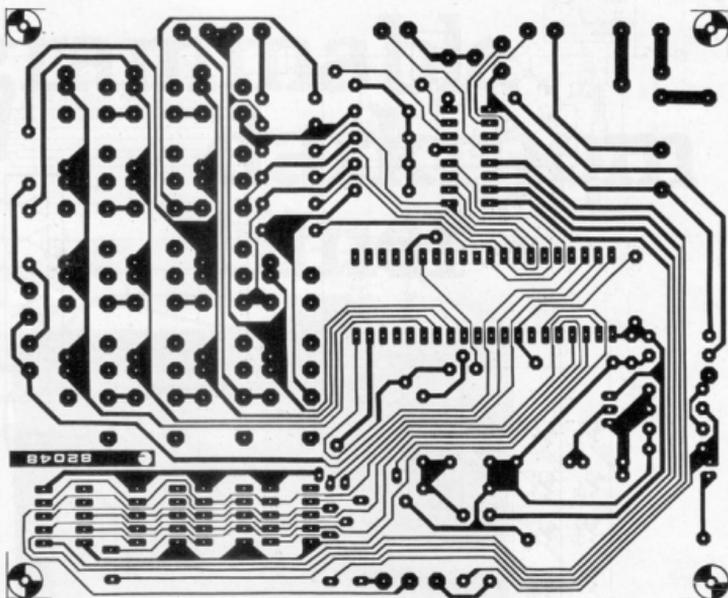

Figure 2. All the components of the darkroom timer can be mounted on this p.c. board (except the mains transformer, piezo-electric buzzer and lamps).

left of the display (LD4) is incremented by 1. Simultaneously the memory contents appear on the three right-hand positions of the display (LD1 . . . LD3). The most significant position is displayed by LD3. A '7' at LD4 is followed by a '1' when the key is pressed.

SET/CLEAR: pressing this key prepares the processor for data input into the memory via the numeric keys '0' . . . '9'. The display is set to '000'. The entered data are displayed step-by-step from right to left. If a numeric key is pressed for the fourth time, this value appears in LD1 and so on. Entry is terminated by pressing any non-numeric key. The display readout is automatically stored and there is therefore no need for an ENTER or DATA STORE key. Protection against incorrect entries is provided by the fact that the processor only responds to a numeric key if the SET/CLEAR key has previously been pressed.

FOCUS: this key can be used to switch the relay on and off at the output of the processor. This facility makes it possible to adjust the enlarger before starting the exposure. The relay remains in that condition until this key is pressed again, or until the exposure is started by pressing the START key.

START/STOP: as its name implies, this key is used to start or stop the exposure. Countdown of the displayed time begins when the key is released. An exposure in progress is immediately stopped by pressing this key. Care should be taken to press the key only briefly, otherwise the process starts again after a certain delay. The relay operates and the program is sequenced to the next programmed time. The START/STOP key can also be bridged with a footswitch, and is the only key which is operational when an exposure is in progress.

Numeric keys 0 . . . 9: data can be entered with these keys. The SET/CLEAR key must previously have been pressed. The entered data are shown on the display from right to left. The number just entered is shifted across the display from right to left and overwrites the previous number. The keys can be pressed any number of times. However, only the last three entries are displayed and stored. Unless the SET/CLEAR key has first been pressed, pressing the numeric keys will have no effect.

Apart from this free programming using the keys described, some functions can be permanently selected using switches.

Diode D4 sets the internal timebase to a clock frequency of 50 Hz.

Diode D5 is switched on with switch S18 if the processor is only to process *one time*. When this time has elapsed, therefore, sequencing does not take place to the next programmed time. Instead, LD4 continuously displays a '1' and when the time has elapsed, LD1 . . . LD3 display the previously selected time once again. The ADVANCE key is not operational in this case.

Via S15a, diode D3 establishes whether or

not the time can be programmed in the 1 s or in the 0.1 s scale. This results in a display range of either 1 . . . 999 s or 0.1 . . . 99.9 s. S15b switches over the decimal point.

Via S16a, diode D2 establishes whether the programmed times are to run automatically or manually. Automatic means that when the start key is pressed, times 1 . . . 7 will run successively. This automatic run only stops when the seventh time has elapsed. The first time is then displayed again and the keyboard is operational once more. In this case the relay is switched off with S16b.

An example of an application using this mode is its use as a process timer in a photographic laboratory. If one selects a time of 10 min at position 5, 0.5 min at position 6, and 3 min at position 7, the developer bath, the stop bath and fixer bath for the film can be timed in that sequence starting with time 5. The times should always be arranged so that the last time to be programmed is at position 7. Otherwise the timer continues to run and one can lose track of the times to be monitored.

The buzzer emits a beep 10 s before a programmed time elapses. When the time has elapsed, the buzzer beeps twice.

Darkroom timer

The description of the programming already contains all the information needed to operate the darkroom timer. The additional hardware is shown in figure 1. This circuit consists of little more than the timer IC, keyboard, display, diodes and switches for fixed programming. IC1 can directly drive the segments of the display. The cathodes of the 7-segment readouts are driven via IC2. Of the remaining three drivers in IC2, two control a piezo-electric buzzer (this can be switched off with S17, and P1 is used to adjust its volume) and one drives the relay for switching the two lamps (enlarger and darkroom lighting). Display outputs D0 . . . D3 are connected to the keyboard via diodes and are also routed to the buzzer in an OR operation. This results in a beep with each keystroke.

R4 and C4 at pin 8 of IC1 ensure that the display is automatically reset to '1000' when the operating voltage is switched on. The 50 Hz signal for the timebase reaches the timer IC via R1 . . . R3, C5 and T1. The power supply with voltage regulator IC3 provides the 12 V operating voltage. Although IC3 becomes very warm, it does not require a heatsink. After insertion, this IC is bent so that the metal surface faces upwards.

The printed circuit board accepts almost the entire circuit (figure 2). The only external connections required are from the transformer and buzzer to the p.c.b. and from the relay contact to the lamps. If desired, a foot-switch can also be connected in parallel with S4.

The 'Talking clock' presented by Elektor in the June 1982 issue only speaks when instructed to do so. In order to hear the time, it is therefore necessary to press the talk button. The following extension makes the circuit more convenient and the time is announced every hour.

talking-clock extension

Table 1. Minutes ones

Digit	Signal	M.O.	f	g
0	1	1	1	0
1	0	1	0	0
2	1	1	1	0
3	1	1	0	0
4	0	1	0	1
5	1	0	0	1
6	1	0	1	1
7	1	1	0	0
8	1	1	1	1
9	1	1	0	1

Table 2. Minutes tens

Digit	Signal	M.T.	f
0	1	1	1
1	0	0	0
2	1	1	0
3	1	0	0
4	0	0	1
5	1	0	1

E.A.J. Bogers

The speech generator IC (IC1 in figure 4 of the Elektor June 1982 issue) receives its time information via flip/flops IC2 . . . IC5. This is the information for the minutes and minute tens, hours and hour tens. The information for the minutes and minute tens which are present at the control inputs of the speech generator IC are listed in tables 1 and 2. At every full hour (at XX.00) the minutes information M.O.f and M.O.g is '1-0' and at M.T.e and M.T.f it is '1-1'. These logic signals only appear in this combination once in the tables. It is therefore merely necessary to start the speech generator IC with this information combination.

The signals required are designated as follows in the circuit diagram (figure 4 of June 1982 issue): 'H' for M.T.f, 'G' for M.T.e, 'E' for M.O.f and the inverted signal 'A' for M.O.g. The inverted signal 'A' is available at pin 9 of IC5. The four signals are subjected to a logic operation via the AND-gate of figure 1. The output of gate N1 is a logic 1 when the minutes indicate

'00'. The RC network between gates N1 and N2 suppresses the small interfering pulses created by the IRQ routine of the clock. As a result of the feedback provided by R3, gate N2 acts as a Schmitt trigger.

Should this more talkative clock become irritating, it can be silenced by setting switch S1 to position 'b'. The connecting points G, H, E, pin 9 of IC5, ALARM, +5 V and 0 V in figure 1 are connected to the corresponding points on the speech board (for example, +5 V to the positive terminal of C13).

One minor imperfection must be taken into account. The time is announced if the date is queried on the hour and the clock is then switched back to the time display. As soon as the display indicates XX.00 again, the automatic time announcement becomes operational. The adjusting of switching times can also result in time announcements. In order to suppress this, switch S1 should simply be set to position 'b'.

1

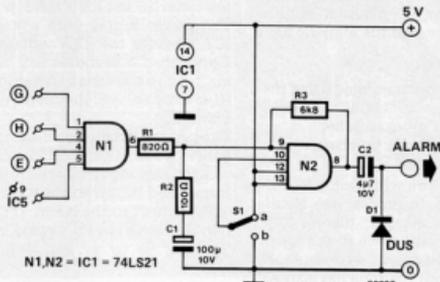
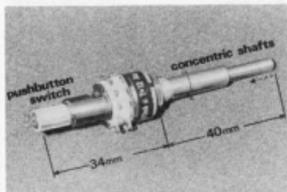

Figure 1. This is the circuit for automatic hourly announcements of the time.

Multiminiswitch

Adding to the wide range of applications already in existence for rotary wafer switches, N.S.F. have taken a miniature rotary wafer switch and an ultra-miniature pushbutton switch, forming them into one dual-action component.

Basing this arrangement upon a concentric shaft, the outer controls the rotary movement and activation of a model MX, 30° indexing switch whilst the inner provides the linear movement necessary to operate the UMO momentary action pushbutton switch.



The length dimension from the mounting face to the end of the pushbutton body is 34 mm and the diameter of the MX wafer is a mere 17 mm.

Applications for such a versatile dual-action switch includes the control of electronic latching circuits.

*N.S.F. Limited,
Keighley,
Yorkshire BD1 5EF.
Telephone: 05352 61144*

(2562 M)

MEC 75 — mini super switch

The MEC 75 switch module has been developed in order to provide a printed circuit board mounting switching module with a very high degree of versatility. In a package measuring only 15 mm x 15 mm no less than 6 different contact functions are possible simply by selecting the

appropriate pins with the printed circuit board design. The MEC 75 is designed to fit the standard 0.1 inch grid pattern and is available in both momentary and alternate key action, both with tactile feel.

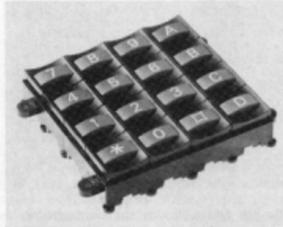

The Unimec keycap system again allows maximum versatility by providing buttons and bezels for the switch. Bezels can accommodate 1 or 2 high brightness 'pin-head', or rectangular bar LEDs, or without LED illumination as desired. The bezels are designed to allow for maximum mounting density in any configuration, using a 0.1 inch grid printed circuit board. Particular attention has been paid to the aesthetic design of the keycap and bezel combination and they are available in 10 attractive colours as standard.

The Vario-Support system is a variable mounting frame that enables the switch range to be panel mounted and eliminates the necessity of a printed circuit board. The Vario-Support system is available in any cell combination from 1 x 1 up to a 10 x 10 matrix.

*MEC 75,
54 Poplar Grove,
Maidstone,
Kent ME16 0AN.
Telephone: 0622 674947.*

(2618 M)

Slimline Counter

Instant installation, regardless of voltage, is available with the latest electronic counter developed by Trumeter. Their new slimline counter is a universal totalising counter, which is only 16 mm thick and is ready for surface mounting, requiring only two small panel mounting holes. It has flying lead connections and, without adjustment, is suitable for a supply voltage range from 6 V DC up to 240 V AC, using a battery or mains supply.



Clearly readable 12 mm high figures read up to 19999 and the whole unit measures only 43 mm high by 79 mm across and 16 mm deep. The casing will cover most existing panel cut outs and the counter is the ideal immediate replacement counter in control panels etc.

Count rate is up to 50 counts per second and the counter has high noise immunity CMOS logic. Operation is entirely noiseless and the LCD display is easily readable in ambient light conditions.

*Trumeter Company Ltd.,
Milltown Street,
Radcliffe,
Manchester M26 9NX.
Telephone: 061 724.6311.*

(2617 M)

'Flat' analogue panel meters

The new Tableau series announced by Anders Electronics Limited represents a fundamental re-think of analogue panel meter design. Not just a cosmetic alternative to traditional design, but a major change of approach — 'flat' meters without barrels.

To accommodate the size of traditional movements, virtually all previous panel meter case designs have included a rear barrel projection. The resulting complexities of a panel cut-out and the restrictions imposed by the intrusion of the barrel into the equipment interior have confronted design and production engineers over the years. By starting with a completely new movement design, the Tableau series avoids these disadvantages. At the heart of the meter is a new ultra-thin 'sandwich' type moving coil movement. Built around a rugged taut-band suspension, this movement is said to meet or exceed the performance of most earlier designs and will withstand shock testing at 200 G. The natural low-friction properties of the taut-band approach leads to an overall linearity better than 1.5%. Standard sensitivities are from 100 μ A

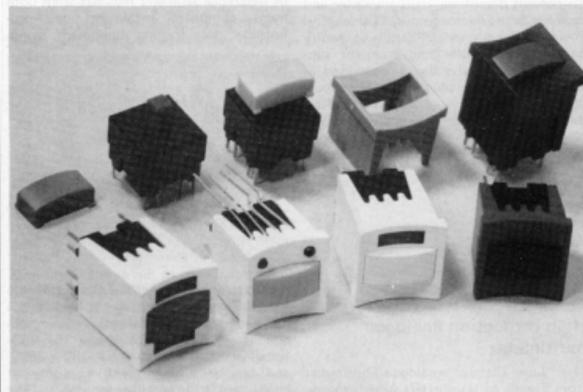

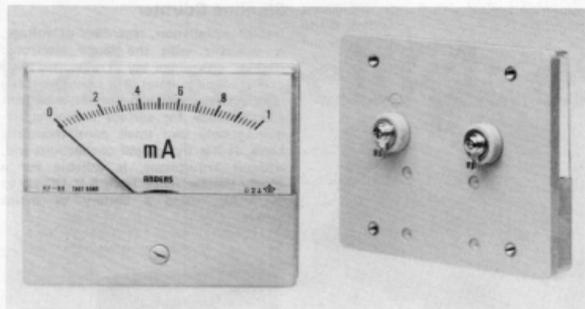

upwards and special ranges or scales are available on request.

The slim style case is just 14 mm thick and has a flat back surface, except for two terminals which serve as mounting studs and electrical inputs. Only two 10 mm diameter clearance holes are needed in the host panel to accommodate the terminals, which are electrically isolated from the panel. The Tableau series is initially available in three sizes; 49 mm square, 68 x 59 mm and 88 x 74 mm; having scale lengths of 34, 46 and 63 mm respectively.

Anders Electronics Ltd.,
48-56 Bayham Place,
London NW1 0EU.
Telephone: 01 387-9092.

(2622 M)

Tiny rotary pre-set switch

The N.S.F. rotary pre-set switch is a compact, switchable link for snap mounting into printed circuit boards and operated by a standard 3 mm screwdriver. The housing size is only 10 mm dia. x 3.5 deep. The design enables actuation from either end of the rotor thus affording equipment designers a high degree of flexibility, especially

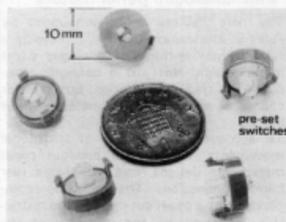

where operation is from outside the equipment via an access hole in the casing. Two and three position models are available rated at 100 mA 50 V.

N.S.F. Limited,
Keighley,
Yorkshire, BD21 5EF.
Telephone: 0535.61144.

(2626 M)

New power plug helps computers

Microcomputers suffering from amnesia need no longer be terminal cases!

Spikes and holes in the domestic mains electricity supply (caused by switching off and switching on electrical equipment) can create havoc for microprocessor users — at worst, a complete crash, at best, a corruption of vital data.

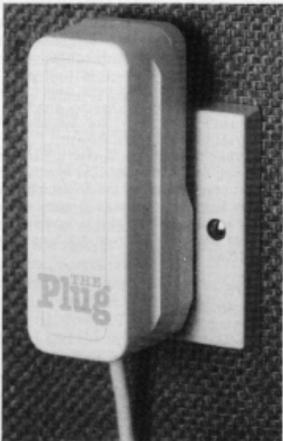

To prevent downtime, reprogramming and to enhance the microcomputer's reliability, Power International's 'PLUG' — a neatly packaged RFI filter and transient suppressor of innovative design contained in a modified 13 amp plug case — effectively absorbs spikes in the power line and reduces their voltage to a tolerably safe level. As a total cost of \$ 15.50 (including post, packing and VAT) the treatment ensures a healthy and happy computer at a very low cost.

Power International Ltd.,
2A Isambard Brunel Road,
Portsmouth,
Hants.
Telephone: 0705.756715.

(2623 M)

High protection analogue multimeter

The 'Super Electro' Analogue Multimeter from Eiemic of Italy offers superb styling

and presentation combined with wide-ranging specifications in 57 ranges and features 50,000 V protection on all ranges. With voltage measurements to 1000 V (DC and AC) and current to 30 A (DC and AC) together with resistance and capacitance ranges, the 'Super Electro' also



provides phase sequence detection for three phase systems and a mains and insulation tester. Based on a high precision, moving coil microammeter, the 'Super Electro' has coloured scales, an anti-parallax mirror and is complete with high quality lined protective case, fused test leads and a years guarantee. With 20 K Ω /V sensitivity and DC accuracy of 1.5% f.s.d., the 'Super Electro' offers exceptional specifications for £ 39.95 (+ VAT).

Black Star Ltd.,
9A Crown Street,
St. Ives,
Huntingdon,
Cambs PE17 4EB.

Telephone: 0480 62440.

(2619 M)

Solenoid operated cassette mechanism

In deference to many requests from both home computer enthusiasts and professional data logging equipment manu-



facturers for a low cost DC controllable cassette mechanism, Ambit is launching a range of such mechanisms at the forthcoming All Electronics Show. The illustrated mechanism, is the AMBTN-3600, and can be supplied with a variety of heads to suit the end user application. The

phase response is not optimised. Toko's thick-film low pass filters are available

standard version is equipped with a stereo record/playback and erase head, although a wide range of combined record/replay heads are also available. Motor operation is from 12 V DC, with less than 0.08% RMS wow and flutter, with the record and playback specification largely determined by the heads selected and the drive circuitry provided. Ambit also offers a range of multi-capstan, multi-motor decks for high performance applications.

Ambit International,
200 North Service Road,
Brentwood,
Essex CM14 4SG.

(2620 M)

Small illuminated pushbutton switches

A new range of small illuminated push-button switches and matching indicators is now available from N.S.F.

Single and double pole, double throw models are available with momentary or push-push actuation. The cylindrical housing measures 12 mm. dia x 24.7 mm from the mounting face, while the buttons are either 14 mm square with an 11.6 illuminated area or 14 mm dia, with an 11.6 dia. illuminated area. Illuminated models are available for either incandescent lamps or LED lamps with single element or double (including an IC chip), in red, yellow and green.

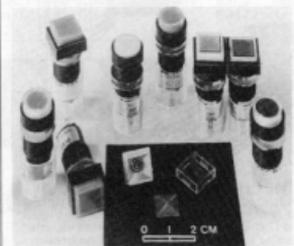

Normal colour coding of actuators is based upon 5 colours — red, yellow, green, blue and white which can be illuminated with an incandescent lamp. But combinations of red, green or yellow LED with differing filter can provide a wide variety of visual effects e.g. a single element red LED when used with a yellow diffusing cap produces a light brown effect.

N.S.F. Limited,
Keighley,
Yorkshire BD21 5EF.
Telephone: 0535.61144.

(2627 M)

Thick film filters

Toko have introduced a range of 20 kHz low pass active filters, specifically for the digital audio market: the PAL 0900 series. The imminent arrival of the Digital Audio Disk has focussed much attention on the A/D and D/A designs required, but the low pass filter is probably one of the most critical points from the serious 'hifi' listener's point of view — since the perfection of the PCM process can be completely squandered at the simple LPF stage if the



with a variety of terminating impedances, all with carefully optimised group delay, and with stopband attenuations up to -95 dB. Samples, data and applications advice is available from Ambit.

Ambit International,
200 North Service Road,
Brentwood,
Essex. CM14 4SG.

(2628 M)

Battery powered wire wrap tool

OK have introduced a battery powered version of the Just Wrap tool, the BJW-3. In the patented Just Wrap process, a specially designed bit compresses insulated wire against the wrap post so that the post edge cuts through the insulation and makes reliable contact with the wire conductor. This allows the user to wrap directly from a wire reel or spool without precutting and prestripping, and makes it possible to wire continuous strings across any number of points with a single continuous insulated wire. The string may be ended at any point with a built in cut-off mechanism. The new BJW-3 is powered by two rechargeable batteries and features a rugged ABS housing and hardened steel components for performance and durability.

It comes complete with a specially designed bit and sleeve, and a 100 ft (30 m) spool

of 30 AWG (0.25 mm) wire. Refill spools are available in 100 ft (30 m) lengths and in 4 colours, blue, red, white and yellow.

OK Machine & Tool (UK) Ltd.,
Dutton Lane,
Eastleigh,
Hants, SO5 4AA.

Telephone: 0703.610944. (2625 M)

Safe Storage for Data Cassettes

The new Fischer C Box Drawer Unit has been specially designed for the owners of personal computers who are looking for safe and easily accessible storage facilities for their data cassettes that contain long term information — or games. The cassette rests in a spring loaded C Box that opens at the touch of a button and incorporates splined hubs to prevent slackening of the tape. Ten interlocked, individual C Boxes with easy-change labels are securely housed in this compact drawer unit that stacks neatly on shelves or next to the VDU. Two designs available: Standard and deluxe (lockable). Available from sole importers at £17.50 and £19.50 incl. VAT and p & p.

Artur Fischer (UK) Limited,
25 Newtown Road,
Marlow,
Bucks. SL7 1JY.
Telephone: 06284.72882. (2616 M)



Step-by-step fully illustrated assembly and fitting instructions are included together with circuit descriptions. Highest quality components are used throughout.

Sparkrite

BRANDLEADING ELECTRONICS
NOW AVAILABLE IN KIT FORM

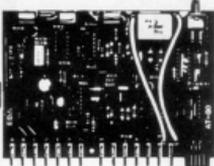

AT-80 Electronic Car Security System

- Arms doors, boot, bonnet and has security loop to protect fog/spot lamps, radio/tape, CB equipment
- Programmable personal code entry system
- Armed and disarmed from outside vehicle using a special magnetic key fob against a windscreen sensor pad adhered to the inside of the screen
- Fits all 12V neg earth vehicles
- Over 250 components to assemble

VOYAGER Car Drive Computer

- A most sophisticated accessory
- Utilises a single chip mask programmed microprocessor incorporating a unique programme designed by EDA Sparkrite Ltd
- Affords 12 functions centred on Fuel, Speed, Distance and Time
- Visual and Audible alarms, warning of Excess Speed, Frost/Ice, Lights left on
- Facility to operate LOG and TRIP functions independently or synchronously
- Large 10mm high 400ft-L fluorescent display with auto intensity
- Unique speed and fuel transducers giving a programmed accuracy of + or - 1%
- Large LOG & TRIP memories: 2,000 miles, 180 gallons, 100 hours
- Full Imperial and Metric calibrations
- Over 300 components to assemble
- A real challenge for the electronics enthusiast!



SX1000 Electronic Ignition

- Inductive Discharge
- Extended coil energy storage circuit
- Contact breaker driven
- Three position changeover switch
- Over 65 components to assemble
- Patented clip-to-coil fitting
- Fits all 12v neg earth vehicles

TX1002 Electronic Ignition

- Contactless or contact triggered
- Extended coil energy storage circuit
- Inductive Discharge
- Three position changeover switch
- Distributor triggerhead adaptors included
- Die cast waterproof case
- Clip-to-coil or remote mounting facility
- Fits majority of 4 & 6 cyl, 12V, neg. earth vehicles
- Over 145 components to assemble

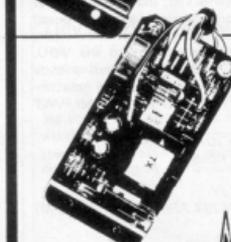

SX2000 Electronic Ignition

- The brandleading system on the market today
- Unique Reactive Discharge
- Combined Inductive and Capacitive Discharge
- Contact breaker driven
- Three position changeover switch
- Over 130 components to assemble
- Patented clip-to-coil fitting
- Fits all 12v neg. earth vehicles

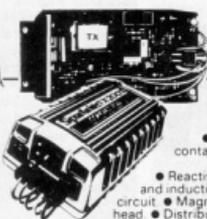

TX2002 Electronic Ignition

- The ultimate system
- Switchable contactless
- Three position switch with Auxiliary back-up inductive circuit
- Reactive Discharge Combined capacitive and inductive
- Extended coil energy storage circuit
- Magnetic contactless distributor triggerhead
- Distributor triggerhead adaptors included
- Can also be triggered by existing contact breakers
- Die cast waterproof case with clip-to-coil fitting
- Fits majority of 4 and 6 cylinder 12v neg. earth vehicles
- Over 150 components to assemble

All SPARKRITE products and designs are fully covered by one or more World Patents.

SPECIAL OFFER

"FREE" MAGIDICE KIT WITH ALL ORDERS OVER £45.00



MAGIDICE Electronic Dice

- Not an auto item but great fun! for the family
- Total random selection
- Triggered by waving of hand over dice
- Beeped flashes during a 4 second tumble sequence
- Throw displayed for 10 seconds
- Auto display of last throw, 1 second on 5
- Muting and OFF switch on base
- Hours of continuous use from P/P7 battery
- Over 100 components to assemble

SPARKRITE 82 Bath Street, Walsall, West Midlands, WS1 3DE England

Tel (0922) 614791 Allow 28 days for delivery

	SELF ASSEMBLY KIT
SX 1000	£12.95
SX 2000	£19.95
TX 1002	£22.95
TX 2002	£32.95
AT 80	£32.95
VOYAGER	£64.95
MAGIDICE	£9.95

PRICES INC. VAT POSTAGE & PACKING

NAME _____
ADDRESS _____

I ENCLOSE CHEQUE(S)/POSTAL ORDERS FOR

£ _____ KIT REF _____

CHEQUE NO _____



BRANDLEADING BRITISH ELECTRONICS
ELEKTOR

CUT OUT THE COUPON NOW!

elektor BUYERS GUIDE

ETESON ELECTRONICS

WE STOCK... A WIDE RANGE OF COMPONENTS
CASES & MULTIMETERS
VERO PRODUCTS
BABANI BOOKS
SOLDERING IRONS, TOOLS,
& MUCH MUCH MORE.

15B Lower Green Poulton-le-Fylde BLACKPOOL. Tel. 885107

Electronic Component Specialists

WATFORD ELECTRONICS

34/35 CARDIFF ROAD, WATFORD, HERTS, ENGLAND
MAIL ORDER, CALLERS WELCOME
Tel. Watford (0923) 40588. Telex: 8956095

ELEKTOR PROJECTS — we stock most of the parts.



ACE MAILTRONIX LTD.,
3A, COMMERCIAL STREET,
BATLEY, WEST YORKS, WF17 5HJ
PHONE 0924-441129
TELEX. 51458 COMHUD G for CHABLE

Suppliers of a wide range of electronic components, to professional and amateur users.
Trade/Retail counter open 9-5.30 weekdays and to 1pm Saturdays.
Catalogues available. Retail 30p. Industrial - Free.

BI-PAK

P.O. BOX 6, WARE, HERTS.
SHOP AT 3 BALDOCK STREET, WARE, HERTS.
TEL. (0920) 3182.
ACCESS & BARCLAYCARD ACCEPTED.

ELECTRONIC WORLD LIMERICK

Parnell Street Limerick

Republic of Ireland

Tel. 061-4 1233

FRANK MOZER LTD.

Specialists in all Electronic, Television
and Radio Component Parts

5 Angel Corner Parade
Edmonton, N.18

Telephone:
01-807 2784

please mention Elektor when ordering goods or requesting information

for your copies of Elektor

THE ELEKTOR CASSETTE BINDER

This cassette style binder will help to keep your copies of Elektor clean and in order, even though you refer to them time and time again. The chamfered corner of the cassette allows instant recognition of each month's issue without the need to thumb through pages of previous months' issues. Because no wires or fasteners are used copies can be easily removed and replaced and each cassette will hold one year's volume of Elektor. Their smart appearance will look good on any laboratory shelf.

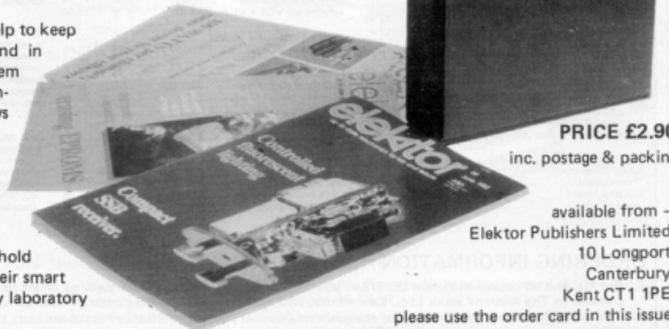

PRICE £2.90
inc. postage & packing

available from —
Elektor Publishers Limited,
10 Longport,
Canterbury,
Kent CT1 1PE.

please use the order card in this issue.

Cheap imitations?



Microdocto

is an alternative to AUTOMATIC TEST EQUIPMENT which can be very expensive. MICRODOCTO is perfectly adequate for diagnosing faults in microprocessor boards or computers in the REPAIR SHOP or on the PRODUCTION LINE. Reports are PRINTED on the integral thermal printer. Tests supported are CHECKSUM, RAMTEST, WAIT, READ, WRITE, I/O READ, I/O WRITE, DUMP IN HEX, DUMP IN ASCII, TEST DATA LINES (for shorts between data, address and rails), SEARCH (for two specified bytes), MAP (print a memory map of ROM, RAM, I/O and EMPTY SPACE). Supports both multiplexed and non-multiplexed address/data. Standard software will also DISASSEMBLE in Z80 mnemonics - other disassemblers cost extra. Programs for board-testing can be written in MINUTES - and retained for MONTHS even if the power is switched off (CMOS RAM is backed-up with rechargeable battery). Capacity is 15 different programs of 12 tests each. Included are two PROBE CONFIGURATION CARDS (one Z80, other uncommitted), PROBE with 24 inch cable and 40-pin DII, plug - and POWER SUPPLY. Extras available are 6502 disassembler retrofit ... £35. 6800 disassembler retrofit ... £35. Thermal paper £9.00 box of 10 Clip-over PROBE (only needed if uP is soldered-in) ... £35. Spare cards ... £6.50

£295
+VAT

New product new concept

Reduced price



The Menta Z80 Development System

uses the MOST POWERFUL LANGUAGE OF ALL - direct ASSEMBLER MNEMONICS. MENTA has VISUAL AIDS to program development which the big systems lack: a TV display of PROGRAM, REGISTERS and STACK, single-step operation (watch the cursor move from instruction to instruction, see the register-contents change, observe stack operations, etc.) BUGS can be fixed immediately without reassembling. Full speed operation is supported too - with or without BREAKPOINTS. Designed originally for the Schools' Council to teach microprocessing, MENTA is a complex CONTROLLER in its own right, like any other Z80 system, with practical, commercial applications in ROBOTICS. Features include CASSETTE INTERFACE, ASSEMBLER/EDITOR, serial DISASSEMBLER (now included as standard), 24 bits of I/O - also TV FLYLEAD, POWER SUPPLY and COMPREHENSIVE MANUAL with SOURCE-CODE LISTING.

£99
+VAT

Goodies from Dataman

Olivetti Typewriter Interfaces

for ET121 and ET221 machines which permit the typewriter to be used as a DAISY WHEEL PRINTER for computers implementing the RS232, IEEE 488 (PET) or CENTRONICS PARALLEL buses: almost all computers in fact. Great for word processing and letter-writing! Same price, fitting free if requested (you pay carriage on typewriter if we fit) ... **£195.00**

Mandar Logic Analyser Enhancements

The THANDAR TA2080 LOGIC-ANALYSER was NOT designed by DATAMAN - but we like this instrument and use it for product development. When using the software we use SOFTY for ROM-EMULATION, following the program-flow on the TA2080 screen. We modified our TA2080 to make it more useful; adding an RS232 OUTPUT TO PRINTER - also Z80 and 6502 DISASSEMBLERS. Now we can follow program operation in MNEMONICS on-screen and print TIMING or STATE DIAGRAMS and DISASSEMBLED CODE. Cost of this RETROFIT kit (12K of program ROM, socket for RS232, interface board, instruction sheet) is, if fitted by us and purchased with a TA2080 ... **£195.00**
if purchased as a kit without TA2080 ... **£295.00**

Softy 1 with PSN

Yes, we still have a few old faithful 3 rail EPROM PROGRAMMERS around, as seen in Kensington Science Museum, if you are still using 2708's get yours!! This fine old classic at a bargain price (telephone for stock pos.) ... **£95.00**

Ultra-Violet Eprom Erasers from

£33.00



Softy Eprom Programmer/Emulator

SOFTY has functions equal, at least, to equipment which sells for over £500. SOFTY EMULATES and PROGRAMS 2716, 2516, 2732, 2532 EPROMS. (The type is selected by a personality switch. SOFTY will copy any of these EPROMS to any other). SOFTY has a HEX KEYPAD, a test CASSETTE INTERFACE, a MEMORY MAP TV DISPLAY with powerful editing - such as INSERT, DELETE, SHIFT-BLOCK and many other facilities - too many to list here. RS232 SERIAL and CENTRONICS PARALLEL routines for INPUT and OUTPUT are standard. The price includes TV FLYLEAD, EMULZ, SOF, E and PSN DII PLUG. DEVELOPMENT ducts or just as a OM PROGRAMMER.

£169
+VAT

Dataman Designs

LOMBARD HOUSE,
CORNWALL ROAD,
DORCHESTER, DORSET DT1 1RX.
Telephone: Dorchester (0305) 68066
Telex 418442 DATAMAN

Prepaid orders normally shipped by return.
Prices include local delivery (recommended post in UK,
Securix or Red Star, etc. at extra cost
VAT should be added at current rates.

All our own work!
Dataman

SPEECH SYNTHESISER FOR ZX81 and VIC20

THE MAPLIN TALK-BACK

Now your computer can talk!

- ★ Allophone (extended phoneme) system gives unlimited vocabulary.
- ★ Can be used with unexpanded VIC20 or ZX81 — does not require large areas of memory.
- ★ In VIC20 version, speech output is direct to TV speaker with no additional amplification needed.
- ★ Allows speech to be easily included in programs.

Complete kit only £24.95.

Order As LK00A (VIC20 Talk-Back).

LK01B (ZX81 Talk-Back).

Full construction details in Maplin Projects Book 6.
Price 70p. Order As XA06G (Maplin Mag Vol. 2 No. 6).

KEYBOARD WITH ELECTRONICS FOR ZX81



- ★ Full size, full travel keyboard that's simple to add to your ZX81 (no soldering in ZX81).
 - ★ Complete with electronics to make "Shift Lock" "Function" and "Graphics 2" single key selections.
 - ★ Powered (with adaptor supplied) from ZX81's own standard power supply.
- Full details in Project Book 3 (XA03D) Price 60p.
Complete kit (excl. case) £19.95. Order As LW72P.
Case £4.95. Order As XG17T.
Ready built-in case £29.95. Order As XG22Y.

OTHER KITS FOR ZX81

- 3-Channel Sounds Generator (Details in Book 5).
Order As LW96E. Price £10.95.
- ZX81 Sound On Your TV Set (Details in Book 6).
Order As LK02C. Price £19.95.
- ZX81 I/O Port gives two bi-directional 8-bit ports (Details in Book 4).
Order As LW76H. Price £9.25.
- ZX81 Extended-board will accept 16K RAM and 3 other plug-in modules.
PCB: Order As GB08J. Price £2.32.
Edge Connectors (4 needed):
Order As RK35Q. Price £2.39.

HOME SECURITY SYSTEM

Six independent channels — 2 or 4 wire operation. External horn. High degree of protection and long term reliability. Full details in Projects Book 2.
(XA02C) Price 60p



MATINEE ORGAN

Easy-to-build, superb specification. Comparable with organs selling for up to £1000. Full construction details in our book (XH55K). Price £2.50. Complete kits available: Electronics (XY91Y) £299.95. Cabinet (XY93B) £99.50. Demo cassette (DX43W) £1.99.



*Cassette extra

25W STEREO MOSFET AMPLIFIER



- ★ Over 20W/channel into 8 Ω at 1kHz both channels driven
 - ★ Frequency response 20Hz to 40kHz \pm 1dB
 - ★ Low distortion, low noise and high reliability power MOSFET output stage.
 - ★ Extremely easy to build. Almost everything fits on main pcb, cutting interwiring to just 7 wires (plus toroidal transformer and mains lead terminations)
 - ★ Complete kit contains everything you need including pre-drilled and printed chassis and wooden cabinet.
- Full details in Projects Book 3. Price 60p (XA03D).
Complete kit only £55.20 incl. VAT and carriage (LW71N).

BUY IT WITH MAPCARD

Send now for an application form — then buy it with MAPCARD. MAPCARD gives you real spending power — up to 24 times your monthly payments, instantly.

All prices include VAT & carriage. Please add 50p handling charge to orders under £5 total value.



MAPLIN'S FANTASTIC PROJECTS

Full details in our project books. Issues 1 to 5: 60p each. Issue 6: 70p.

- In Book 1 (XA01B) 120W rms MOSFET Combo-Amplifier • Universal Timer with 18 program times and 4 outputs • Temperature Gauge • Six Vero Projects.
- In Book 2 (XA02C) Home Security System • Train Controller for 14 trains on one circuit • Stopwatch with multiple modes • Miles-per-Gallon Meter.
- In Book 3 (XA03D) ZX81 Keyboard with electronics • Stereo 25W MOSFET Amplifier • Doppler Radar Intruder Detector • Remote Control for Train Controller.

In Book 4 (XA04E) Telephone Exchange for 16 extensions • Frequency Counter 10Hz to 600kHz • Ultrasonic Intruder Detector • I/O Port for ZX81 • Car Burglar Alarm • Remote Control for 25W Stereo Amp.

In Book 5 (XA05F) Modem to European standard • 100W 240V AC Inverter • Sounds Generator for ZX81 • Central Heating Controller • Panic Button for Home Security System • Model Train Projects • Timer for External Sounder.

In Book 6 (XA06G) Speech Synthesiser for ZX81 & VIC 20 • Module to Bridge two of our MOSFET Amps to make a 350 W Amp • ZX81 Sound on your TV • Scratch Filter • Damp Meter

MAPLIN'S NEW 1983 CATALOGUE

Over 390 pages packed with data and pictures and all completely revised and including over 1000 new items. On sale in all branches of WHSMITH. Price £1.25



Post this coupon now!

Please send me a copy of your 1983 catalogue. I enclose £1.50 (inc p&p). If I am not completely satisfied I may return the catalogue to you and have my money refunded. If you live outside the U.K. send £1.90 or 10 International Reply Coupons.

Name _____

Address _____

E483

MAPLIN

MAPLIN ELECTRONIC SUPPLIES LTD.
P.O. Box 3, Rayleigh, Essex S56 8LR
Telephone: Sales (0702) 552911 General (0702) 554155

Shops at: _____ Note: Shops closed Mondays
159 King St., Hammersmith, London W6. Telephone: 01-748 0926
284 London Rd., Westcliff-on-Sea, Essex. Telephone: (0702) 554000
Lynton Square, Perry Barr, Birmingham. Telephone: (021) 356 7292